

INSTRUCTION BOOK

LOAD BREAK INTERRUPTER SWITCH TYPE PIF, FRAME MOUNTED For Mounting in Metal-Enclosed Structures Conforming to ANSI C37.20.3

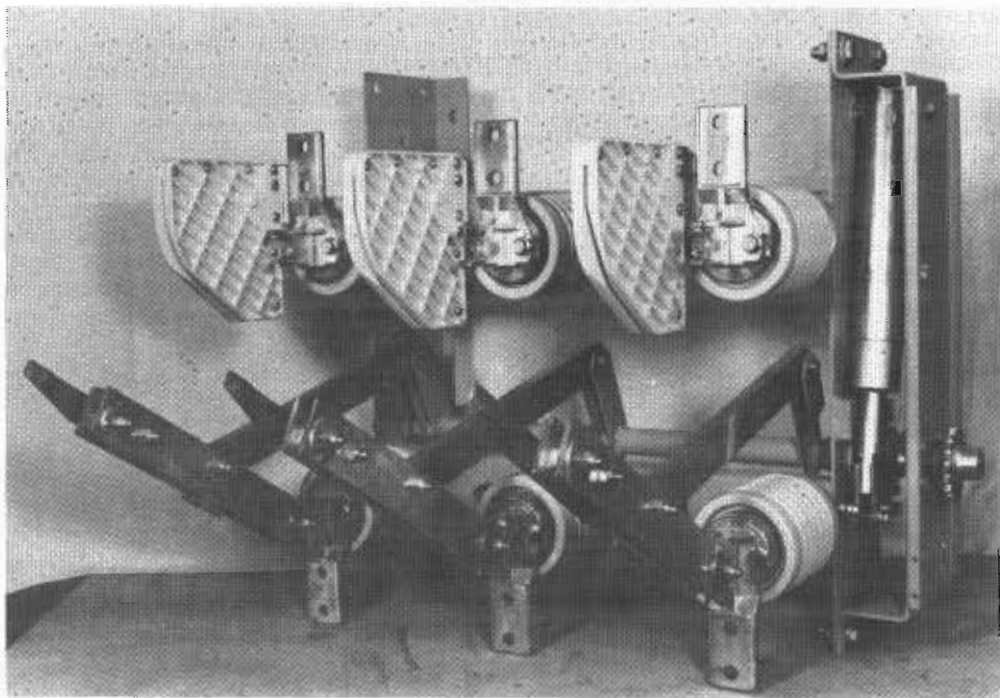

RATINGS

**5 kV and 15 kV
600A and 1200A**

**3-POLE SINGLE THROW
60 kV, 75 kV, 95 kV and 110kV BIL**

These instructions may not cover all details or variations in equipment, nor provide for every possible contingency encountered. Should further information be desired or should problems arise which are not covered sufficiently the matter should be referred to the POWERCON CORPORATION.

GENERAL WARNINGS

WARNING

IT IS IMPERATIVE THAT YOU READ AND COMPLETELY UNDERSTAND THE WARNINGS LOCATED THROUGHOUT THIS INSTRUCTION BOOK. FAILURE TO DO SO, CAN RESULT IN DAMAGE TO PROPERTY, PERSONAL INJURY OR DEATH.



DO NOT REMOVE COVERS, OPEN DOORS, OR WORK ON EQUIPMENT UNLESS POWER HAS BEEN TURNED OFF AND ALL CIRCUITS DE-ENERGIZED AND DISCONNECTED. DISCONNECT, DE-ENERGIZE, LOCK-OUT AND PROPERLY GROUND CIRCUIT(S) BEFORE WORKING ON THIS EQUIPMENT. USE PROPER SAFETY PRECAUTIONS WHEN WORKING ON THIS EQUIPMENT.

ALL SAFETY CODES, SAFETY STANDARDS AND/OR REGULATIONS AS THEY MAY BE APPLIED TO THIS TYPE OF EQUIPMENT MUST BE STRICTLY ADHERED TO. THE POWER SUPPLY MUST BE DISCONNECTED BEFORE ANY ADJUSTMENTS, SERVICING, PARTS REPLACEMENT OR ANY OTHER ACT IS PERFORMED REQUIRING ANY PHYSICAL CONTACT WITH THE ELECTRICAL COMPONENTS OR WIRING OF THIS EQUIPMENT.

In addition to the personnel precautions as outlined, refer to:



OSHA 29CFR PART 1910 CONTROL OF HAZARDOUS ENERGY SOURCES LOCKOUT/TAGOUT FINAL RULE.

ANSI/NFPA 70E-1988: ELECTRICAL SAFETY REQUIREMENTS FOR EMPLOYEE WORKPLACES.

ANSI/NFPA 70B-1987: ELECTRICAL EQUIPMENT MAINTENANCE



THE EQUIPMENT COVERED BY THIS INSTRUCTION BOOK MUST BE SELECTED FOR A SPECIFIC APPLICATION AND IT MUST BE INSTALLED, OPERATED AND MAINTAINED BY QUALIFIED PERSONS WHO ARE THOROUGHLY TRAINED AND WHO UNDERSTAND ALL OF THE HAZARDS INVOLVED. As with any electrical apparatus the thorough knowledge of the engineering safety inspection, maintenance and repair techniques as well as being familiar with particular features of the apparatus involved is mandatory. THIS BOOK DOES NOT PROVIDE SUFFICIENT INSTRUCTIONS FOR INEXPERIENCED ELECTRICIANS OR UNQUALIFIED PERSONS TO DO ANY WORK REQUIRED INCLUDING THE HANDLING, INSTALLATION, TESTING, OPERATION, INSPECTION, MAINTENANCE, AND REPAIR.



BEFORE ANY CHECKING OR MAINTENANCE OF SWITCHGEAR, AFTER IT HAS BEEN INSTALLED - THE FOLLOWING MUST BE OBSERVED: ONLY QUALIFIED PERSONS MAY OPERATE, INSPECT OR MAINTAIN POWER SWITCHGEAR. In addition to the personnel you may have that are qualified, others may be available from an experienced high voltage contractor or the utility servicing the installation. IT IS THE RESPONSIBILITY OF THE PURCHASER, INSTALLER OR ULTIMATE USER TO INSURE THAT THE WARNING SIGNS ARE NOT REMOVED AND TO MAKE SURE THAT ALL ACCESS DOORS AND OPERATING HANDLES ARE SECURELY LOCKED WHEN THE GEAR IS LEFT UNATTENDED BY QUALIFIED PERSONS, EVEN MOMENTARILY.



SAFETY GROUNDING TO BE DONE ON DE-ENERGIZED EQUIPMENT ONLY

Before energizing the equipment and prior to any testing it is recommended that all circuits be safely grounded. Prior to any grounding whether it be for any testing, inspection, or maintenance procedures, assure that all safety precautions are taken. It is further recommended that an appropriate properly operating glow tube instrument that lights up and warns the worker when held in any alternating current field, indicating the presence of voltage, be used prior to grounding

PERSONNEL DOING SUCH WORK SHOULD WEAR LINEMAN'S PROTECTIVE EQUIPMENT IN ACCORDANCE WITH SUCH EQUIPMENT MANUFACTURER'S RECOMMENDATIONS INCLUDING BUT NOT LIMITED TO PROTECTIVE GLOVES, INSULATED SLEEVES, LINEMAN'S BLANKETS, INSULATED HELMETS, FACE AND EYE PROTECTION that will assist in preventing injury if for any reason the equipment is grounded to an energized circuit. Every precaution should be taken to prevent electrical grounding on an energized circuit. Suitable grounding clamp leads should be used and safety grounding techniques employed. ALL SUCH GROUNDS MUST BE REMOVED AFTER TESTING, INSPECTION, OR MAINTENANCE PRIOR TO ENERGIZING THE EQUIPMENT.

In as much as Powercon has no control over the use to which others may put this material, statements concerning uses of the materials described herein are not to be construed as suitable for these uses unless proper technology in the usage, application, and maintenance are strictly observed. For further information call or write the Powercon Corporation.



LIMITED WARRANTY

Powercon warrants that the equipment delivered by it will be of the kind and quality described in the order or contract and will be free of defects in workmanship and material. Should any failure to conform to this warranty appear within one year after date of shipment, Powercon shall, upon prompt notification thereof and substantiation that the equipment has been stored, installed, operated, and maintained in accordance with Powercon recommendations and standard industry practice, correct such nonconformities, at its option, either by repairing any defective part or parts or by supplying a repaired or replacement part or parts F.O.B. factory. However, if Powercon has installed the equipment or furnished field engineering services with respect to its installation, and provided such installation has not been delayed by the Purchaser, said one year shall run from the completion of the installation. The total warranty period shall not exceed 18 months from the date of shipment in any case.

In no event shall Powercon be responsible for providing working access to the defect, including the removal, disassembly, replacement or reinstallation of any equipment, materials or structures to the extent necessary to permit Powercon to perform its warranty

obligations, or transportation costs to and from the Powercon factory to repair facility. The conditions of any tests shall be mutually agreed upon and Powercon shall be notified of, and may be present at, all tests that may be made.

THE WARRANTIES SET FORTH IN THIS PROVISION ARE EXCLUSIVE AND IN LIEU OF ALL OTHER WARRANTIES WHETHER STATUTORY, EXPRESS OR IMPLIED (INCLUDING ALL WARRANTIES OF MERCHANTABILITY AND FITNESS FOR PARTICULAR PURPOSE AND ALL WARRANTIES ARISING FROM COURSE OF DEALING OR USAGE OF TRADE), EXCEPT OF TITLE AND AGAINST PATENT INFRINGEMENT.

The remedies provided above are the Purchaser's sole remedies for any failure of Powercon to comply with its obligations. Correction of any nonconformity in the manner and for the period of time provided above shall constitute complete fulfillment of all the liabilities of Powercon whether the claims of the Purchaser are based in contract, in tort (including negligence) or otherwise with respect to or arising out of the equipment furnished hereunder.

WARRANTY IMPLEMENTATIONS AND CONDITIONS

On those occasions where service help is required, the Powercon Corporation should be notified at once through its Service Department. No charges or expenses should be incurred except as authorized by the Corporation in writing. Making unauthorized corrections or doing unauthorized work voids this Warranty and renders reimbursement impossible.

At times, the Powercon Corporation may request labor and/or material services from you. At our option we will provide competent supervision who will authorize such services by signing the Time Sheets of the people

involved. No reimbursement can be made without signed Time Sheets.

The services rendered must be of the type and quality satisfactory to the Powercon Corporation, and we reserve the right to reject any and all such services.

The above in no way prejudices the right of the Powercon Corporation to correct, as stipulated in the Warranty, any problems that may occur in equipment manufactured by the Powercon Corporation.

FOREWORD

This Instruction Book is furnished in "As is" condition. No warranties expressed or implied, including warranties of fitness for a particular purpose, or merchantability, or warranties arising from course of dealing or usage of trade are made regarding the information, recommendations, descriptions, and safety notations contained herein. In no way will Powercon be responsible to the user in contract, in tort (including negligence), strict liability or otherwise for any direct special, indirect, incidental, or consequential damage or loss whatsoever, including but not limited to damage or loss of use of equipment, plant, or power system, cost of capital, loss of profits or revenues, cost of replacement

power, additional expenses in the use of existing power facilities, or claims against the user by its customer resulting from the use of information, recommendations, descriptions, and safety notations contained herein.

The information, recommendations, descriptions, and safety notations in this document are based on Powercon's experience and judgement in respect to all of the subject matter contained herein. This information must not be considered to be all inclusive or covering all contingencies.

TABLE OF CONTENTS

	Page
GENERAL WARNINGS	ii
LIMITED WARRANTY	iii
WARRANTY IMPLEMENTATIONS AND CONDITIONS	iii
FOREWORD	iii
TABLE OF CONTENTS	iv
1.0 INTRODUCTION	1
1.1 GENERAL	1
1.2 APPLICATION	1
Table#1 - Indoor Air Interrupter Type PIF Switch Ratings	1
1.3 MINIMUM SAFETY PRACTICES	1
Typical Nameplate	1
2.0 RECEIVING, HANDLING AND STORAGE	2
3.0 INSTALLATION	2
3.1 GENERAL	2
Figure 1 - Switch Mounting Dimensions	2
Figure 2 - Alignment of Outboard Sprocket	3
Figure 3 - Chain Adjustment	3
3.2 INSTALLED SWITCH INSPECTION	3
3.3 SWITCH ALIGNMENT AND ADJUSTMENT PROCEDURE	3
Disconnect Pushrods	3
Figure 4 - Disconnecting Pushrods	3
Main Blade Alignment	3
Figure 5 - Main Blade Alignment	4
Figure 6 - Main Blade to Jaw Contacts Adjustment	4
Figure 7 - Jaw Casting Alignment with Main Blades Adjustment	4
Arcing Blade Alignment	4
Figure 8 - Arcing Blade Alignment	4
Figure 9 - Arcing Blade Adjustment	4
Hinge Contact Pressure Adjustment	4
Jaw Contact Pressure Adjustment	4
Figure 10 - Setting Pull-Off Force	5
Figure 11 - Contact Pressure Adjustment	5
Figure 12 - Checking Pull-Off Force	5
4.0 OPERATION	5
4.1 DESCRIPTION	5
4.2 SEQUENCE OF OPEPATION	5
5.0 MAINTENANCE	5
5.1 GENERAL REQUIREMENTS	5
5.1.1 Periodic Cleaning	5
5.1.2 Cleaning	5
5.1.3 Contact Inspection	5
Warning Tag	6
5.1.4 Insulators	6
5.1.5 Insulation Check	6
5.1.6 Bus Conductor (Switch Blade) Check	6
5.1.7 Chain Drive	6
5.1.8 Operating Shaft	6
5.1.9 Pushrods	6
5.1.10 Stored Energy Mechanism	6
5.1.11 Lubrication	6
5.1.12 High Potential Tests	6
6.0 RENEWAL PARTS	6
7.0 DIMENSIONAL REFERENCE	7
8.0 PIF LOAD BREAK SWITCH INSPECTION, MAINTENANCE AND TEST REPORT	8

1.0 INTRODUCTION

1.1 GENERAL

The Powercon Load Break Interrupter Switch Type PIF represents the latest design in medium voltage high current switching equipment. The simple design of the Stored Energy Mechanism insures positive and constant closing force of main blades even with variations of the manual closing controls. With the addition of electrical operation and overcurrent protection the type PIF Switch provides an economical means of power circuit control and switching suitable for a wide range of application.

1.2 APPLICATION

Powercon Load Break Interrupter Switches, Type PIF, are applied in the control and switching of Power Distribution Systems having nominal a.c. voltage ratings from 2.4 kV to 34.5 kV. They are capable of switching 600 and 1200 amperes. Table #1 lists the applicable limits and conditions of switching. These switches are available with either electrical or mechanical operators. When used in conjunction with fuses they will afford short circuit and disconnect services. These switches are used:

- For protection and isolation of transformers.
- For the protection and isolation of single circuit systems.
- For the protection and isolation of multi-circuit systems.
- For automatic transfer schemes.

Applicable Industry Standards

NEMA SG-5	-	Power Switchgear Assemblies
NEMA SG-6	-	Power Switching Equipment
ANSI C37.20.3	-	Metal-Enclosed Interrupter Switchgear
ANSI C37.30	-	Requirements for High-Voltage Air Switches
ANSI C37.31	-	Indoor Apparatus Insulators (For High-Voltage Switches)
ANSI C37.32	-	Preferred Ratings and Manufacturer Specs for High-Voltage Switches
ANSI C37.33	-	Rated Control Voltages and Ranges for High-Voltage Switches
ANSI C37.34	-	Test Code for High-Voltage Air Switches

1.3 MINIMUM SAFETY PRACTICES



LOAD BREAK INTERRUPTER SWITCH

Type PIF, Model -Pole 60 Hertz
 Rated Volts kV Max. Volts kV, Cont. Amps
 K Amps Asym. Mom., kV BIL
 K Amps Asym. Fault Close
 S/N- Amps, Int. INSTR & R/P - PCIB-1002B

Typical Nameplate



DO NOT EXCEED NAMEPLATE RATINGS OF THIS SWITCH. TO DO SO COULD CAUSE PROPERTY DAMAGE, SEVERE INJURY, OR DEATH.

- 1.3.1 For qualified personnel refer to Page iii of this Instruction Book.
- 1.3.2 Read and understand these instructions before attempting any assembly, operation, or maintenance of the switch.
- 1.3.3 Disconnect all power sources and ground all switch terminals before making any adjustments or performing maintenance.
- 1.3.4 After opening switch and before opening door, use viewing window to insure that all three switch blades are open. If necessary, use a flashlight to verify all three contacts are open.
- 1.3.5 There are several interlocks on the switches. They are for personnel and/or equipment protection. Under no circumstances should they be made inoperative when switch is in service. To do so could cause bodily injury, death, or property damage.
- 1.3.6 Never energize the switch without the arc chutes and barriers installed in place.
- 1.3.7 Always be sure that all switch hardware is in place and tightened properly. Refer to Maintenance Section of this Instruction Book for procedures and details.
- 1.3.8 Make sure all safety interlocks are working properly prior to energizing.

TABLE #1. INDOOR AIR INTERRUPTER TYPE PIF SWITCH RATINGS*
 (These ratings apply to Switches & Equipments with Stored Energy Operated Switches)
 (Special Ratings Available - Consult Factory)

VOLTAGE RATINGS				CURRENT RATINGS				
NOMINAL kV, RMS	MAX. DESIGN kV, RMS	1 MIN. POWER FREQ. WITHSTAND kV, RMS	1.2 x 50 IMPULSE WITHSTAND kV, BIL	CONTIN- UOUS AMPERE, RMS	LOAD INTER- RUPTING AMPERE	SHORT TIME RATINGS		FAULT CLOSE kA, RMS ASYM.
						MOMENTARY ASYM. kA, RMS	3-SEC kA, RMS	
4.16	4.76	19	60	600	600	40	25	40
				1200	1200	61	38	61
7.2	8.25	26	75	600	600	40	25	40
				1200	1200	61	38	61
13.8	15.0	36	95	600	600	40	25	40
				1200	1200	61	38	61
14.4	15.5	50	110	600	600	40	25	40
				1200	1200	61	38	61
23.0	25.8	60	125	600	600	40	25	40
				1200	1200	61	38	61
34.5	38.0	80	150	600	600	40	25	40
				1200	1200	61	38	61
34.5	38.0	95	200	600	600	40	25	40
				1200	1200	61	38	61

*Other Ratings Available - Consult Powercon

2.0 RECEIVING, HANDLING AND STORAGE

Upon receipt of the load break interrupter switch or switchgear, immediately make an examination for any damage or loss sustained in shipment. This pertains to the housing as well as the load break switch and mechanism. If damage, loss, or rough handling is evident, a written damage claim should be filed at once with the transportation company and the Powercon Corporation should be notified at the same time.

Be sure that no loose parts are left in the packaging material. Blow out any dirt or loose particles of packing material on or around the load break switch and mechanism.

Study the erection drawing carefully and check the bill of material to be sure that all parts are at hand.

The shipment should include:

- Three-pole interrupter switch, factory-assembled on a rugged base of welded construction.
- Interphase barriers and side barriers as required.
- Operating handle.
- The appropriate set of operating-mechanism components required for the specific installation including chain, handle, etc.

Before taking the switch from its shipping crate, remove the insulating barriers (if supplied) and set them aside to prevent their being damaged. Barriers are to be attached to the switch only after all other assembly operations are complete and adjustments are satisfactory. Remove also the operating handle mechanism components. Then remove the switch, **LIFTING IT BY THE FRAME**. Make sure that lifting sling does not place any strain on the live parts or insulators.

WARNING

DO NOT, UNDER ANY CIRCUMSTANCES, HANDLE THE SWITCH BY RIGGING ON THE INSULATORS OR LIVE PARTS.

When the unit is not to be placed in service immediately, it should be stored in a clean, dry location and suitably covered. Moisture absorbing material should not be used to cover the equipment, as that could cause corrosion of parts.

During the construction or assembly period the switch should be properly protected against damage due to environmental conditions such as moisture, dirt, cement, rough handling, abrasion.

When dampness or condensation exists, the equipment must be covered with a suitable vented cover to allow moisture to escape. Heaters of 50 watts rating should be placed in each unit to prevent moisture damage.

3.0 INSTALLATION

3.1 GENERAL

The switch is to be installed in a metal-enclosure. Four (4) 3/4" diameter holes in the base of the switch permit the vertical positioning adjustment. Provision should be made in the mounting surface for lateral adjustment. When the switch is mounted in a metal-enclosure, the mounting surface must be flat and true to avoid twisting the switch frame when it is bolted down. Such distortion of the frame can affect the adjustment of switch live parts, necessitating realignment of switch blades. It should also be determined that the enclosure construction is of the proper rigidity to handle the operation/charging of the stored energy mechanism.

1. Use 1/2 inch hardware to bolt the switch to its mounting surface. See Figure 1 for dimensions. To avoid distortion of the switch frame, install the upper mounting bolts first, finger tight; then, at each lower mounting bolt location. Fill any space between the switch frame and the mounting surface with shims. Then torque all mounting bolts to 50 ft-lb. See **WARNING** below.

WARNING

WHEN BUS OR CABLE IS CONNECTED TO THE SWITCH IT IS IMPORTANT THAT NO STRAIN IS PUT UPON THE SWITCH TERMINAL PADS.

SUCH STRAIN CAN DISTORT THE SWITCH'S LIVE PARTS AND MAY RESULT IN IMPROPER SWITCH OPERATION. MAKE SURE, BEFORE MAKING ANY CONNECTION, THAT THE BUS OR CABLE CONNECTION IS ALIGNED WITH AND FLAT AGAINST THE TERMINAL PAD. DO NOT USE THE CONNECTING BOLTS AS A MEANS OF PULLING THE BUS OR CABLE INTO POSITION.

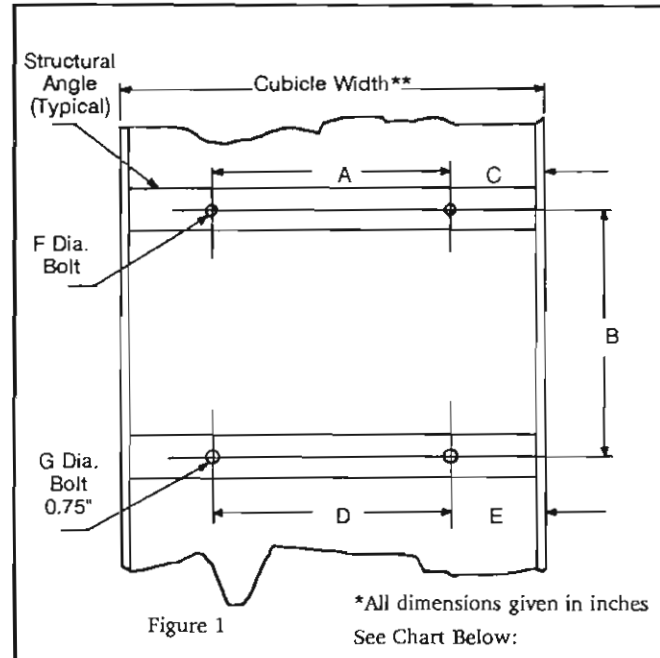

Switch Class	*A	*B	*C	*D	*E	*F
4.16kV, 600A, 60kV BIL, A67	12.76	18.38	7.62	13.24	7.38	0.50
4.16kV, 1200A, 60kV BIL, A67	12.76	18.38	7.62	13.24	7.38	0.50
4.16kV, 600A, 60kV BIL, A61-62	21.24	21.88	7.38	21.24	7.38	0.75
4.16kV, 1200A, 60kV BIL, A61-62	21.24	21.88	7.38	21.24	7.38	0.75
13.8kV, 600A, 95kV BIL, A62	21.24	21.88	7.38	21.24	7.38	0.75
13.8kV, 1200A, 95kV BIL, A62	21.24	21.88	7.38	21.24	7.38	0.75
14.4kV, 600A, 110kV BIL, A62	21.24	21.88	7.38	21.24	7.38	0.75
14.4kV, 1200A, 110kV BIL, A62	21.24	21.88	7.38	21.24	7.38	0.75

2. Position the outboard sprocket of switch as required and align it with the operating-handle sprocket position. Refer to Figure 2.
3. For connecting the operating-handle to switch sprocket determine total length of chain required then cut (1) length 24" for use at the operating handle on the sprocket. Pass the 24" length thru the handle housing and around the the handle sprocket centered on the length of chain on the sprocket. Place the handle in the latched close position - handle up. At this point switch should be closed.
4. For the operating-handle sprocket location, a shorter length of chain is furnished. (A 24-inch length of chain is suggested for switches with main contacts at top. **REMOVE CHAIN LINKS ACCORDINGLY.**) Pass the chain around the handle sprocket such that, with the handle in mid-position, the free ends of the chain are about the same length when extended. Refer to Figure 3. Place the handle in the latched-closed position. If the Handle is "Up" - Switch must be closed.

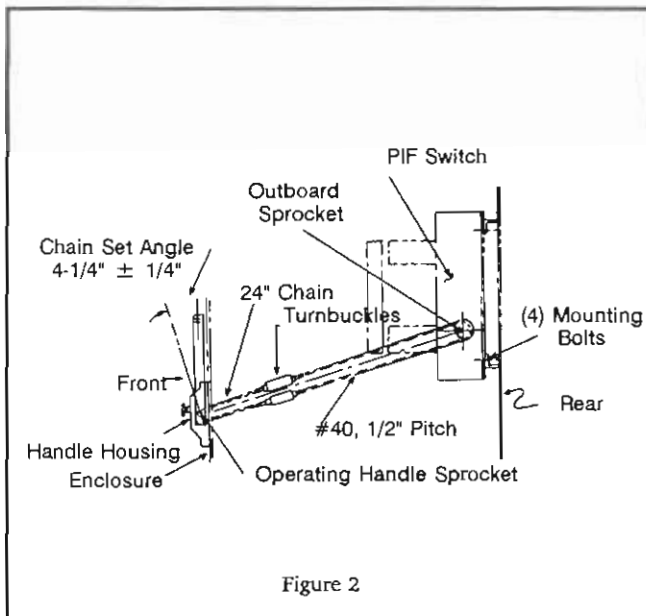

Figure 2

5. Couple turnbuckles to each end of the above chain. Extend each turnbuckle to its maximum length. Then using the longer length of chain provided, connect it to extend from one turnbuckle, around the switch drive sprocket and back to the other turnbuckle. Remove chain links to make the chain about two links longer than required to go from one turnbuckle to the other.

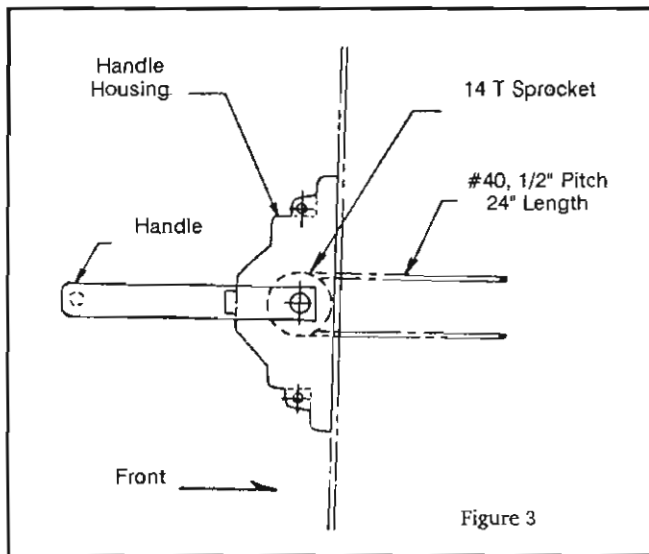

Figure 3

6. Move operating handle approximately $4\frac{1}{4} \pm \frac{1}{4}$ from the vertical handle assembly mounting and hold it in this position. Refer to Figure 2. Connect chains and turn buckles until chain tension is even and fairly tight. Move handle back "up" into its locked-closed position. Do not throw switch "open" at this time.

If the procedures on the preceding pages have been followed, the load break interrupter switch is now ready for operation.

IMPORTANT

THIS IS A SLIDING JOINT. Overtightening can cause the switch not to open and also cause severe damage to the mechanism.

3.2 INSTALLED SWITCH INSPECTION

After installation of the switch the following procedure should be performed to ascertain proper operation. This can be done by opening and closing the switch several times in succession. Do not attempt to grind the blades with powdered emery or other abrasives. Such practice inevitably results in poor contact and overheating.

Switch contact adjustment should be checked as follows:

1. Operate the switch several times checking for main blade and arcing blade alignment with the stationary contacts and arc chute.
2. Check switch resistance by using a low resistance ohm meter connected between the jaw spade terminal and the hinge spade terminals. Do this measurement on each pole of the assembly.

Any low resistance meter capable of measurements in the micro-ohm range may be used. Suitable meters include:

Valhalla Scientific, Inc.	Biddle Instruments
Model 4150 ATC	Cat No. 247350
Digital Ohmmeter	Digital Low Resistance Ohmmeter

If the switch does not move freely or the resistance is over 80 microhms then the switch must be readjusted using the following switch alignment procedure and adjustment procedure.

CAUTION

THE HINGE AND JAW CONTACTS ARE SLIDING JOINTS AND OVERTIGHTENING CAN CAUSE THE SWITCH NOT TO OPEN AND SEVERELY DAMAGE THE MECHANISM.

3.3 SWITCH ALIGNMENT AND ADJUSTMENT PROCEDURE

Step 1. Disconnect Pushrods

Remove cotter pins and clevis pins that connect pushrods to operating arms of each pole of switch. See Figure 4.

NOTE

Access to the clevis pins on 5kV switches may be improved by first opening the switch.

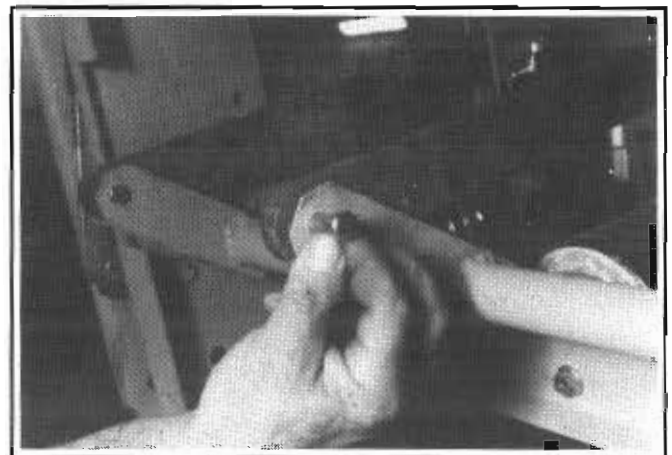

Figure 4

Step 2. Main Blade Alignment

Disengage switch blades by pulling outward on the main switch blade until the main blades are separated from the jaw casting. Continue to pull outward until arcing blade disengages from the arc chute. See Figure 5.

CAUTION

THE ARCING BLADE IS UNDER SPRING PRESSURE AND SNAPS OPEN WHEN CLEAR OF THE STATIONARY ARCING CONTACTS WITHIN THE ARC CHUTE.

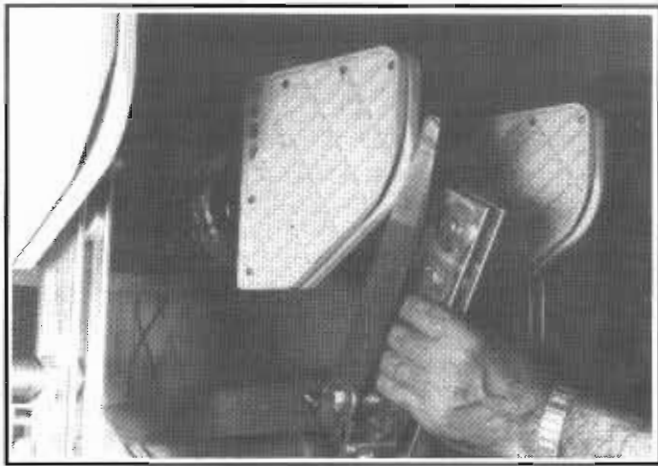

Figure 5

If the main blades do not align with the jaw contacts loosen the hinge casting mounting bolts and move the pole assembly, then re-tighten the bolts. See Figure 6.

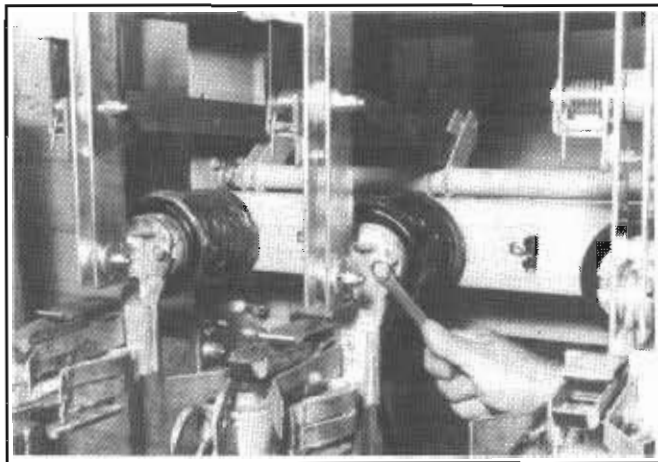

Figure 6

Check that the jaw casting contact surfaces align with the main blades. If necessary to adjust, loosen the jaw casting mounting bolts, tap on the spade terminal to align, then re-tighten the bolts. See Figure 7.

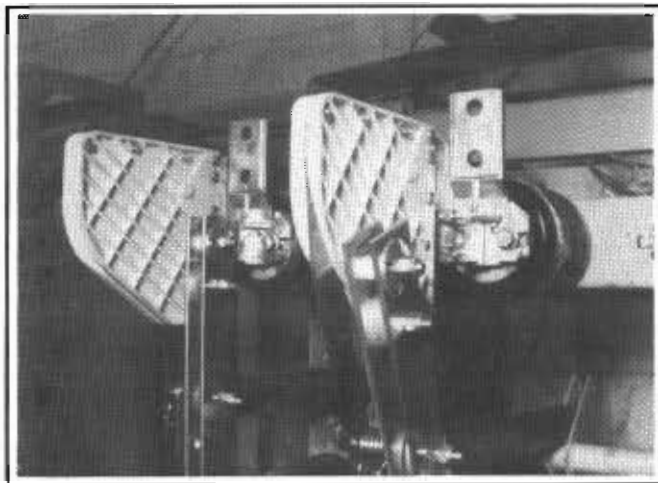

Figure 7

Step 3. Arcing Blade Alignment

Slowly move blade in and out to check for proper alignment of arcing blade with the opening in the arc chute. If necessary, adjustment may be made by loosening the jaw casting mounting bolts and lightly tapping the arc chute mounting bracket. Re-tighten bolts. See Figure 8.

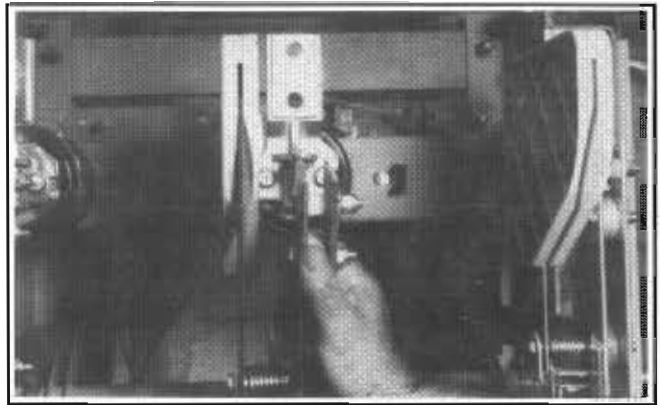

Figure 8

* Any corrections in the arcing blade position necessary (after all previous steps have been completed) may be done by loosening the locknut on the arcing blade adjusting screw - see Figure 9 - and turning screw either in or out to obtain positioning of arcing blade. Re-tighten locknut.

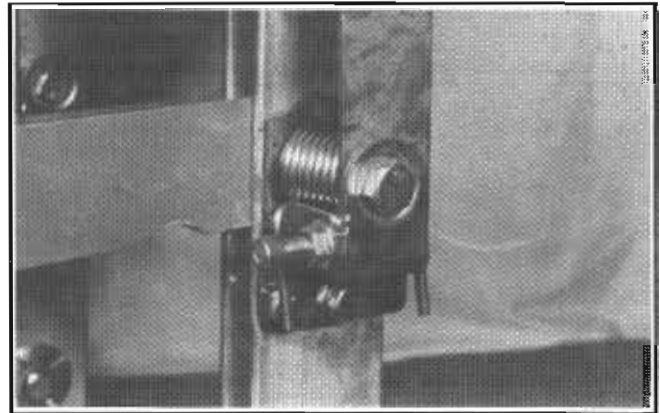

Figure 9

Step 4. Hinge Contact Pressure Adjustment

Open switch until the arcing blade just clears the arc chute. Connect a spring scale to the main blades approximately 1-1/2" below the jaw contact. Some switches are equipped with a spacer just below the jaw. This provides a convenient point to connect the scale. On other switches, use a "tee" adapter allowing equal force on both blades. See Figures 10, 11 and 12.

NOTE

If the nylon insert locknut is removed for any reason, it must be replaced with an "ESNA" stopnut.

A force of 2 - 4 pounds should be necessary to move the blades. Loosen or tighten the hinge bolt as necessary to meet the 2 - 4 pound requirement.

Step 5. Jaw Contact Pressure Adjustment

Close each switch pole and connect a spring scale as described in Step 4. A force of 30 - 36 pounds should be necessary to open the switch blades. Loosen or tighten the jaw contact bolts as necessary to meet the 30 - 36 pound requirement. See Figures 10, 11 and 12 for spring scale placement.

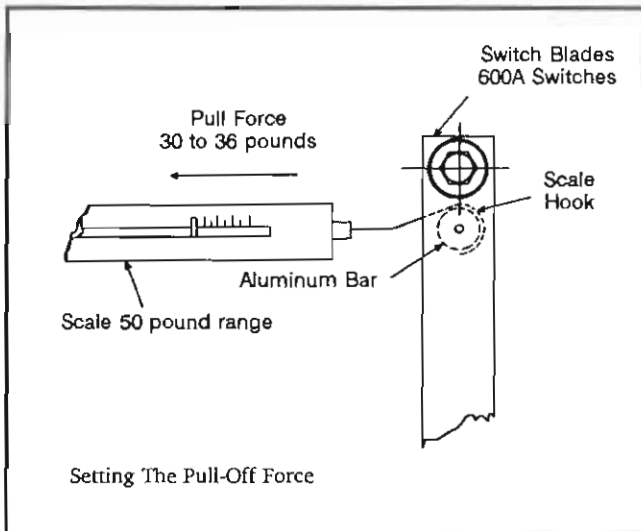

Figure 10

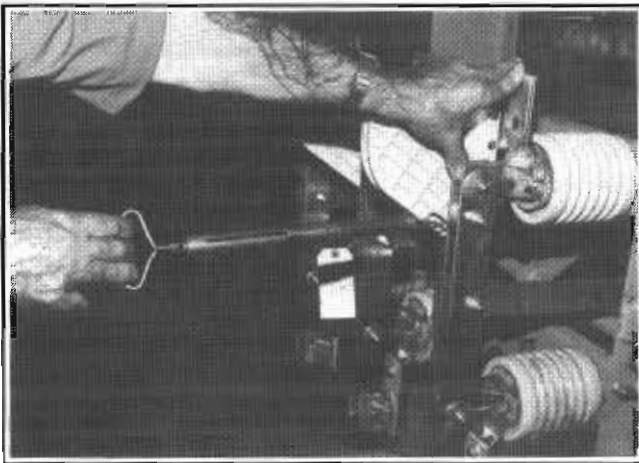

Figure 11

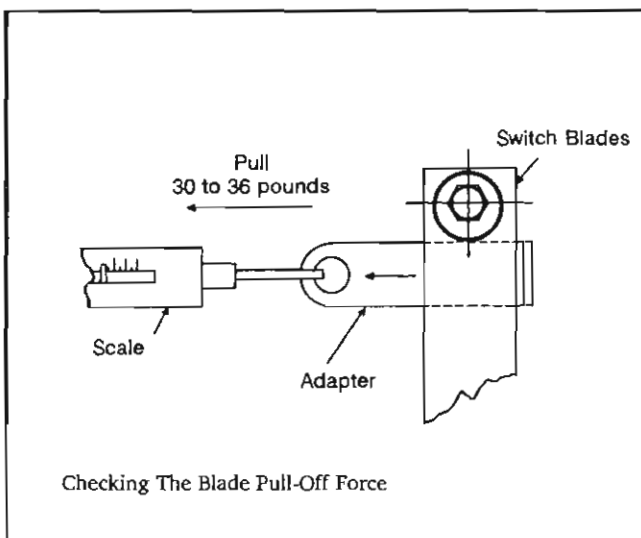

Figure 12

4.0 OPERATION

4.1 DESCRIPTION

The powerful opening and closing springs of Powercon's off-center stored energy mechanism provide for quick make (rated fault closing) and quick break (rated load interruption) operation. The switch mechanism shaft is driven by a chain and sprocket from the front operating handle. As the handle is rotated, it is directly connected to a sprocket which in turn chain drives the opening spring to a "charged" position. As the operator continues to rotate the handle, the charged spring is driven off-center by the chain and releases its energy thereby rotating the operating shaft. The switch blades will not move, in either a closing or opening direction, until the main spring causes rotation in the operating shaft. It should be noted that once the springs are moved off-center, the operator has no further control of the opening or closing operation. Therefore, this mechanism has a fault closing and rated load break feature independent of operator performance.

4.2 SEQUENCE OF OPERATION

Quick Make - Rated Fault Close
Quick Break - Rated Load Interruption

To Open the Switch

- 4.2.1 Pull handle latch button to its extreme position.
- 4.2.2 Move handle toward the lower position about 15 degrees or until a resistive force is felt in the handle. The latch button may now be released.
- 4.2.3 With a swift positive unhesitating force complete the opening stroke. Once the "off-center" stored energy mechanism takes over there is no further control of opening by the operator.
- 4.2.4 Now complete the movement of the operating handle until the latch button seats itself.

To Close the Switch

Closing procedures are the reverse of the above, except the handle is rotated toward the upper position.

Failure to clear latch button lever from the housing mechanism can cause damage and jam the operating mechanism.

5.0 MAINTENANCE

5.1 GENERAL REQUIREMENTS

5.1.1 PERIODIC CHECKING

Load break switches should be examined and checked once a year or sooner when conditions require it (such as numerous operations, polluted atmosphere or overloading of the switch). All switches should occasionally be opened and closed several times in succession, not exceeding their rated duty.

5.1.2 CLEANING

All switches, including insulators and operating arms, should be thoroughly cleaned periodically by wiping with a clean cloth to prevent accumulations of dust. After cleaning, a light coat of lubricant (non-corrosive, high-temperature grease equivalent to SCH-32 Mobiltemp) should be applied to the contact surfaces. Do not use "cup" or other grease which may harden upon exposure to air.

5.1.3 CONTACT INSPECTION

Check to determine that blades made good contact.

A contact resistance measurement between jaw spade terminal and hinge spade terminals should be taken and should be between 35 to 100 micro-ohms. Insure that the blades can be "opened" from jaw casting with a pulling force of approximately 30-36 pounds measured at a point between the main blades just below the jaw contact as previously described.

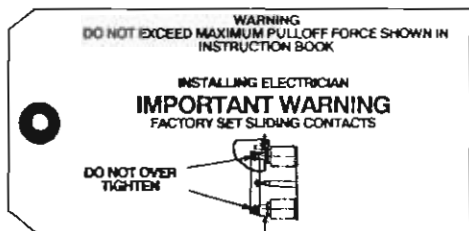

These contacts do not tarnish like copper, but they should be "wiped" clean occasionally, especially if the switch has not been operated for some time. This can be done by opening and closing the switch several times in succession. **DO NOT ATTEMPT TO GRIND THE BLADES WITH POWDERED EMERY OR OTHER ABRASIVES.** Such practice inevitably results in poor contact and overheating.

5.1.4 INSULATORS

It is necessary that the insulators surfaces be kept clean. This is absolutely essential, particularly when the switches are located where cement dust, metallic dust, salt spray, acid fumes and other unfavorable environmental conditions exist. Alcohol cleaner or a light detergent is recommended for cleaning the insulator parts. Make absolutely sure that proper ventilation and other precautions are taken when using any chemical cleaner. Discard and replace any insulators showing signs of treeing or tracking.

5.1.5 INSULATION CHECK

When making an annual check, all insulation should be carefully examined for tracking. Special attention must be given to areas where the conductor passes through an insulator or lays near a barrier. Examine the surface for cracks or streaked discoloration. When tracking is found, the insulation involved must be replaced.

5.1.6 BUS AND CONDUCTOR (Switch Blade) CHECK

Inspect the buses and connections carefully every year for evidence of overheating or damage. It is desirable to measure the resistance to ground and between phases of the insulation of buses and connections with a meter (or use a megger of proper voltage). A record should be kept of this reading. Weakening of the insulation from one maintenance period to the next can be recognized from the recorded readings. At recording time, the record should include the temperature, the humidity, and the date.

5.1.7 CHAIN DRIVE

The chain drive assembly connects the stored energy mechanism to the operating handle on the front of the housing. It consists of a length of roller type chain fastened in a loop by two adjustable turnbuckles with locking nuts.

5.1.8 OPERATING SHAFT

The operating shaft connects the stored energy mechanism to the switch operating arms. The shaft is integral with the switch assembly and is bearing mounted. Light lubricant applied to bearing surfaces will insure trouble free operation. No adjustments are necessary.

5.1.9 PUSHRODS

Each main blade of the switch is connected to the throw arms or the main operating shaft by an insulating pushrod. These pushrods should be examined during each normal maintenance procedure for signs of damage to either end. If a damaged pushrod is encountered, replacement parts may be obtained by referring to **RENEWAL PARTS** section of this Instruction Book.

5.1.10 STORED ENERGY MECHANISM

The stored energy mechanism consists of a housing with a one piece crank sprocket assembly supported by bearings and a spring assembly.

The sprocket assembly is chain driven by means of a handle on the front of the housing. As the handle is moved upward, the spring assembly is charged. As the crank sprocket assembly passes over dead center, the spring takes over and drives the switch to the closed position. The unit is factory adjusted and should need no adjustment in the field. The only moving parts which should be checked after approximately 100 operations are the front and rear latches, which are spring operated, and the two shaft bearings.

Check to make sure the latches rotate freely up and down by using finger pressure on the rollers. Check for loose bearing bolts.

5.1.11 LUBRICATION

The load break interrupter switch requires infrequent lubrication. Bearing points and sliding surfaces should be lubricated at the regular inspection periods with a thin film of low temperature lubricant. Before lubrication, remove any hardened grease and dirt from latch and bearing surfaces with kerosene, varsol, or naphtha.

The contact surface of the movable blades and the stationary contact surface should be cleaned and greased with SCH-32 Mobiltemp.

5.1.12 HIGH POTENTIAL TESTS

High potential tests to check the integrity of the insulation are not necessary if the insulation maintenance instructions in this book are carefully followed. Should the purchaser desire to make high potential tests, the test voltage should not exceed 14 kV A. C. for 4.16 kV and 27 kV A.C. for 13.8 kV. These voltages are 75% of factory test voltages and are in accordance with ANSI standards.

6.0 RENEWAL PARTS

5 and 15kV PIF - 600 and 1200A

The following table is provided as a reference guide to stocking levels of spare parts to minimize downtime when used with a conscientiously applied maintenance program. All items are stock to two weeks. When ordering specify Model Number and Serial Number (S.O.) from the switch nameplate.

RECOMMENDED STOCK FOR FIVE 3-POLE SWITCHES	5 kV		15 kV	
	600A	1200A	600A	1200A
Arc Chute Assembly (3) Catalog# B-2341	X	X	X	X
Hinge Casting (3) Catalog# C-7131	X		X	
Hinge Casting (3) Catalog# C-7326		X		X
Jaw Casting (3) Catalog# C-7130	X		X	
Jaw Casting (3) Catalog C-7325		X		X
Main Blade Assembly (3) Catalog# B-2343-2	X		X	
Main Blade Assembly (3) Catalog# B-2344-2		X		X
Insulator A-20 (4) Catalog# C-7684			X	X
Insulator A-20 (4) Catalog# 164210E	X	X		
Barrier (1) Set of 4 Catalog# S.O.#	X	X	X	X
Barrier Spacer (1) Set of 4 Catalog# S.O.#	X	X	X	X
Insul. Link Assem.(Pushrods) (1) Set of 3 Catalog# B-1572X			X	X
Insul. Link Assem.(Pushrods) (1) Set of 3 Catalog# B-1573X	X	X		

2 Hole (Optional)
4 Hole (Standard)

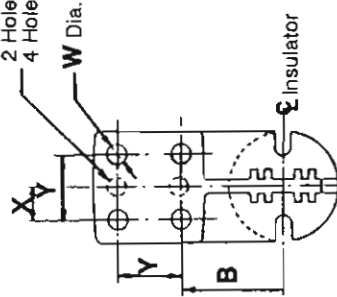

FOR 1200A SWITCH

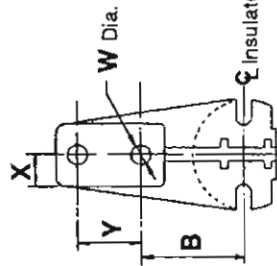

FOR 600A SWITCH

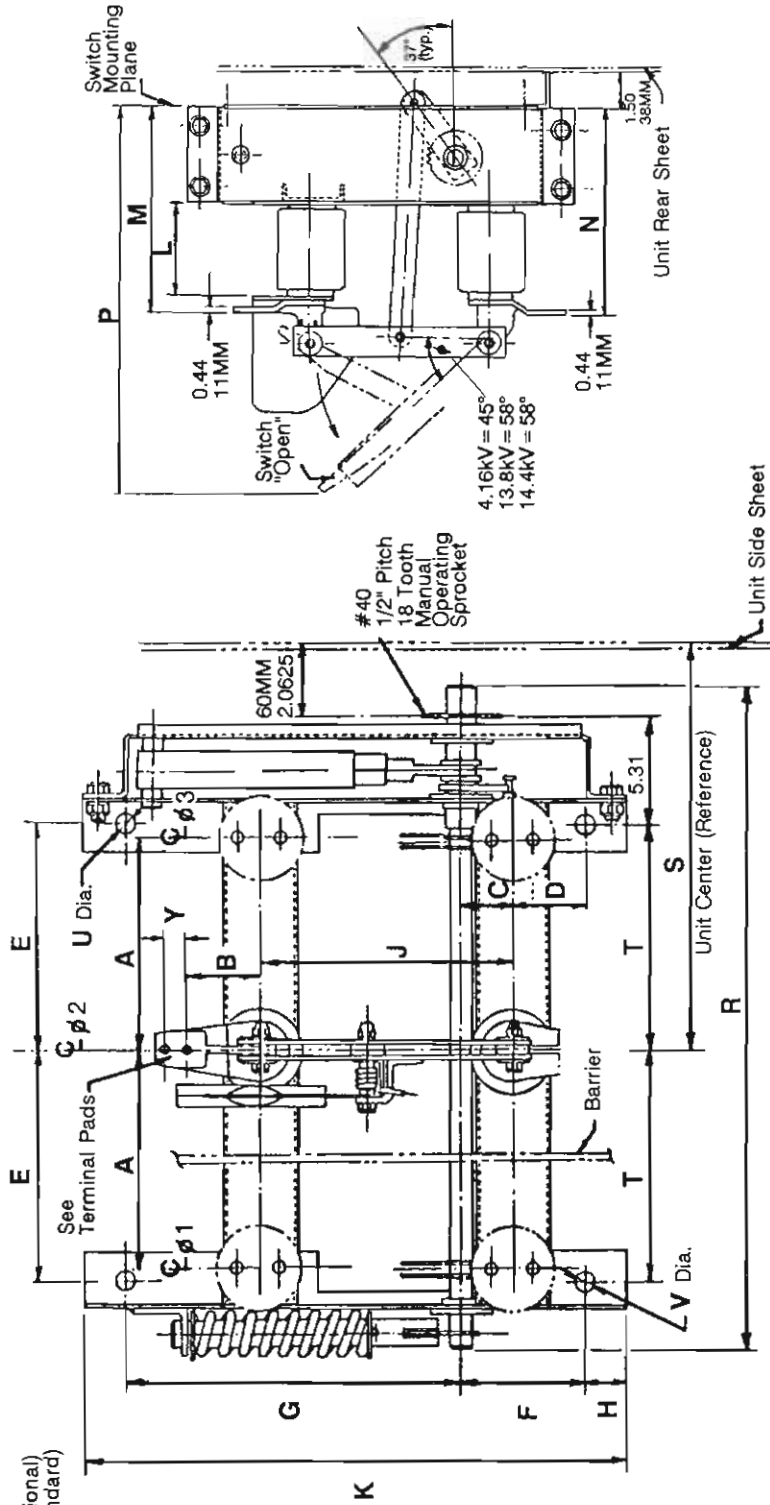

FRONT VIEW

SIDE VIEW

SWITCH CLASS	Units	A	B	C	D	E	F	G	H	J	K	L	M	N	P	R	S	T	U	V	W	X	Y
4.16kV, 600A, 60kV BIL, A67	IN	6.00	2.75	2.50	3.50	6.38	6.00	12.38	2.00	12.0	25.88	3.50	10.81	10.62	23.0	22.38	14.0	6.62	0.5	0.75	0.56	0.81	1.75
	MM	152	70	63.5	89	162	152	315	51	305	657	89	275	270	584	569	356	168	13	19	14	21	45
4.16kV, 1200A, 60kV BIL, A67	IN	6.00	2.75	2.50	3.50	6.38	6.00	12.38	2.00	12.0	25.88	3.50	10.81	10.62	23.0	22.38	14.0	6.62	0.5	0.75	0.56	0.88	1.75
	MM	152	70	63.5	89	162	152	315	51	305	657	89	275	270	584	569	356	168	13	19	14	22	45
4.16kV, 600A, 60kV BIL, A61-62	IN	10.0	2.75	2.50	3.50	10.62	6.00	15.88	2.00	12.0	25.88	3.50	10.81	10.62	23.0	30.88	18.0	10.62	0.75	0.75	0.56	0.81	1.75
	MM	254	70	63.5	89	270	152	403	51	305	657	89	275	270	584	784	457	270	19	19	14	21	45
4.16kV, 1200A, 60kV BIL, A61-62	IN	10.0	2.75	2.50	3.50	10.62	6.00	15.88	2.00	12.0	25.88	3.50	10.81	10.62	23.0	30.88	18.0	10.62	0.75	0.75	0.56	0.88	1.75
	MM	254	70	63.5	89	270	152	403	51	305	657	89	275	270	584	784	457	270	19	19	14	22	45
13.8kV, 600A, 95kV BIL, A62	IN	10.0	2.75	2.50	3.50	10.62	6.00	15.88	2.00	12.0	25.88	6.00	13.31	13.12	27.6	30.88	18.0	10.62	0.75	0.75	0.56	0.81	1.75
	MM	254	70	63.5	89	270	152	403	51	305	657	152	338	333	701	784	457	270	19	19	14	21	45
13.8kV, 1200A, 95kV BIL, A62	IN	10.0	2.75	2.50	3.50	10.62	6.00	15.88	2.00	12.0	25.88	6.00	13.31	13.12	27.6	30.88	18.0	10.62	0.75	0.75	0.56	0.88	1.75
	MM	254	70	63.5	89	270	152	403	51	305	657	152	338	333	701	784	457	270	19	19	14	22	45
14.4kV, 600A, 110kV BIL, A62	IN	10.0	2.75	2.50	3.50	10.62	6.00	15.88	2.00	12.0	25.88	7.50	14.88	14.69	29.1	30.88	18.0	10.62	0.75	0.75	0.56	0.81	1.75
	MM	254	70	63.5	89	270	152	403	51	305	657	191	378	373	739	784	457	270	19	19	14	21	45
14.4kV, 1200A, 110kV BIL, A62	IN	10.0	2.75	2.50	3.50	10.62	6.00	15.88	2.00	12.0	25.88	7.50	14.88	14.69	29.1	30.88	18.0	10.62	0.75	0.75	0.56	0.88	1.75
	MM	254	70	63.5	89	270	152	403	51	305	657	191	378	373	739	784	457	270	19	19	14	22	45

TERMINAL PADS

7. DIMENSIONAL REFERENCE

**8. PIF LOAD BREAK SWITCH INSPECTION,
MAINTENANCE AND TEST REPORT**

LOAD BREAK DISCONNECT SWITCH

CUSTOMER:	TYPE: <input type="checkbox"/> PIF
LOCATION:	PLATING: <input type="checkbox"/> SILVER <input type="checkbox"/> TIN
IDENTIFICATION:	SERIAL NO:
VOLTAGE CLASS: <input type="checkbox"/> 5 kV <input type="checkbox"/> 15 kV	AMPS: <input type="checkbox"/> 600 <input type="checkbox"/> 1200 <input type="checkbox"/> _____ (Specify)

MECHANICAL INSPECTION

A. Switch Blades and Arc Blades

- Check torque on insulator mounting bolts to switch frame.
(25-30 Ft.-Lb. torque range recommended).
- Check torque on bolts mounting castings to insulators.
(25-30 Ft.-Lb. torque range recommended).
- Inspect for proper arc blade alignment to arc chute contacts.
Section 3.3 Page 4.
- Check arc blade alignments with arc chutes.
Section 3.3 Page 4.
- Inspect silver plating on switch blades.
- Check switch blade alignment with jaw casting contact.
Section 3.3 Pages 3 and 4.
- Check switch blade pull off pressure at jaw casting contact.
Section 3.3 Pages 4 and 5.
- Check switch blade pull off pressure at hinge.
Section 3.3 Pages 4 and 5.
- Inspect contact grease on casting contacts.
Section 5.1.2 Page 5 and Section 5.1.11 Page 6.
- Check for proper alignment of switch assembly in cubicle.

B. Insulators and Pushrods

- Check pushrods for cracks, deformities, or tracking.
- Check pushrods for complete coverage of insulating varnish.
- Insure cotter pin fasteners are spread apart.
- Inspect porcelains for defects, deformities, or tracking.
- Check for tightness of nut on operating arms.

C. Handle Mechanisms

- Check chain on mechanism for proper tension.
Section 3.1 Pages 2 and 3.
- Check handle "Pull to Operate" knob for freedom of movement.
- Check handle positioning top and bottom of housing.
Section 3.1 Pages 2 and 3.
- Check handle unit for nameplates (Open, Close, Pull to Operate)

D. Miscellaneous Inspection Items

- Check latches for free movement and spring return action.
Section 5.1.10 Page 6.
- Check weld of main shaft to "A" cam assembly.
- Check bearings for proper lubrication.
- Check lubrication of plunger and tube assembly.
- Check rebound spring for proper lubrication.

E. Test

- Contact resistance. (Post Values Below*)
- Blade pull-off . Section 3.3 Pages 4 and 5. (Post Values Below*)

*	CONTACT RESISTANCE (Micro-ohms)	BLADE PULL-OFF (Lbs.)
ØA		
ØB		
ØC		

REMARKS

- [1] Visual
- [2] Blade Pull-off 30-36 Lbs-Force.
- [3] 2-4 Lbs Pull On Blades Will Start Blades To Rotate
- [4] Contact Resistance Of 80 Micro-ohms Max (For Installation)
between Hinge And Jaw Spade Terminals-Section 3.2 Page 3.
Contact Resistance of 100 Micro-ohms Max (For Maintenance)
between Hinge and Jaw Spade Terminals-Section 5.1.3 Page 5.

Inspector:
Approved: Manager Quality Control
Date:



P. O. Box 477
1551 Florida Avenue
Severn, Maryland 21144

Baltimore: 410-551-6500
Washington: 301-621-7400
Toll Free: 1-800-838-5055
Fax: 410-551-8451