



1551 Florida Avenue (P. O. Box 477)  
Severn, Maryland 21144  
Baltimore 410-551-6500  
Washington 301-621-7400  
Fax 410-551-5481 • Telex 87-476

PCIB-1013C  
(9/1/92)

## INSTRUCTION BOOK

# MOTOR DRIVE SYSTEM

FOR

## POWERCON PIF FRAME MOUNTED INTERRUPTER SWITCHES

**Note: This Book Must Be Used in Conjunction With PCIB-1008  
(Latest Edition)**

### WARNING

**FOLLOW THE SAFETY INSTRUCTIONS AND WARNINGS THROUGHOUT  
THIS BOOK. FAILURE TO DO SO CAN RESULT IN DAMAGE TO  
PROPERTY, PERSONAL INJURY, OR DEATH.**

**IN ADDITION TO THE MAINTENANCE AND PRECAUTIONS AS  
OUTLINED WITHIN, REFER TO ANSI/NFPA 70 B**

**These instructions may not cover all details or variations in equipment, nor provide for every possible contingency encountered. Should further information be desired or should specific problems arise which are not covered sufficiently, the matter should be referred to the POWERCON CORPORATION.**



1551 Florida Avenue (P. O. Box 477)  
Severn, Maryland 21144  
Baltimore 410-551-6500  
Washington 301-621-7400  
Fax 410-551-5481 • Telex 87-476

PCIB-1013C  
(9/1/92)

## INSTRUCTION BOOK

# MOTOR DRIVE SYSTEM

FOR

## POWERCON PIF FRAME MOUNTED INTERRUPTER SWITCHES

**Note: This Book Must Be Used in Conjunction With PCIB-1008  
(Latest Edition)**

### WARNING

**FOLLOW THE SAFETY INSTRUCTIONS AND WARNINGS THROUGHOUT  
THIS BOOK. FAILURE TO DO SO CAN RESULT IN DAMAGE TO  
PROPERTY, PERSONAL INJURY, OR DEATH.**

**IN ADDITION TO THE MAINTENANCE AND PRECAUTIONS AS  
OUTLINED WITHIN, REFER TO ANSI/NFPA 70 B**

These instructions may not cover all details or variations in equipment, nor provide for every possible contingency encountered. Should further information be desired or should specific problems arise which are not covered sufficiently, the matter should be referred to the POWERCON CORPORATION.

## DANGER-HAZARDOUS VOLTAGE

### WARNING IMPORTANT

IT IS IMPERATIVE THAT YOU READ AND COMPLETELY UNDERSTAND THE WARNING LOCATED TO THE RIGHT OF THIS BLOCK. FAILURE TO DO SO CAN RESULT IN DAMAGE TO PROPERTY, PERSONAL INJURY OR DEATH.

**DO NOT REMOVE COVERS, OPEN DOORS, OR WORK ON EQUIPMENT UNLESS POWER HAS BEEN TURNED OFF AND ALL CIRCUITS DE-ENERGIZED AND DISCONNECTED. DISCONNECT, DE-ENERGIZE, LOCK-OUT AND PROPERLY GROUND CIRCUIT(S) BEFORE WORKING ON THIS EQUIPMENT. USE PROPER SAFETY PRECAUTIONS WHEN WORKING ON THIS EQUIPMENT.**

## SAFETY

### WARNING IMPORTANT

IT IS IMPERATIVE THAT YOU READ AND COMPLETELY UNDERSTAND THE WARNING LOCATED TO THE RIGHT OF THIS BLOCK. FAILURE TO DO SO CAN RESULT IN DAMAGE TO PROPERTY, PERSONAL INJURY OR DEATH.

**ALL SAFETY CODES, SAFETY STANDARDS AND/OR REGULATIONS AS THEY MAY BE APPLIED TO THIS TYPE OF EQUIPMENT MUST BE STRICTLY ADHERED TO. THE POWER SUPPLY MUST BE DISCONNECTED BEFORE ANY ADJUSTMENTS, SERVICING, PARTS REPLACEMENT OR ANY OTHER ACT IS PERFORMED REQUIRING ANY PHYSICAL CONTACT WITH THE ELECTRICAL COMPONENTS OR WIRING OF THIS EQUIPMENT.**

**IN ADDITION TO THE PERSONNEL PRECAUTIONS AS OUTLINED, REFER TO:**

### WARNING IMPORTANT

IT IS IMPERATIVE THAT YOU READ AND COMPLETELY UNDERSTAND THE WARNING LOCATED TO THE RIGHT OF THIS BLOCK. FAILURE TO DO SO CAN RESULT IN DAMAGE TO PROPERTY, PERSONAL INJURY OR DEATH.

### ***Z244.1-1982 PERSONNEL PROTECTION LOCKOUT/TAGOUT OF ENERGY SOURCES MINIMUM SAFETY REQUIREMENTS***

**BEFORE ANY CHECKING OR MAINTENANCE OF SWITCHGEAR, AFTER IT HAS BEEN INSTALLED - THE FOLLOWING MUST BE OBSERVED: ONLY QUALIFIED PERSONS MAY OPERATE, INSPECT OR MAINTAIN POWER SWITCHGEAR. IN ADDITION TO THE PERSONNEL YOU MAY HAVE THAT ARE QUALIFIED, OTHERS MAY BE AVAILABLE FROM AN EXPERIENCED HIGH VOLTAGE CONTRACTOR OR THE UTILITY SERVICING THE INSTALLATION. IT IS THE RESPONSIBILITY OF THE PURCHASER, INSTALLER OR ULTIMATE USER TO INSURE THAT THE WARNING SIGNS ARE NOT REMOVED AND TO MAKE SURE THAT ALL ACCESS DOORS AND OPERATING HANDLES ARE SECURELY LOCKED WHEN THE GEAR IS LEFT UNATTENDED BY QUALIFIED PERSONS, EVEN MOMENTARILY.**



## LIMITED WARRANTY

Powercon warrants that the equipment delivered by it will be of the kind and quality described in the order or contract and will be free of defects in workmanship and material. Should any failure to conform to this warranty appear within one year after date of shipment, Powercon shall, upon prompt notification thereof and substantiation that the equipment has been stored, installed, operated, and maintained in accordance with Powercon recommendations and standard industry practice, correct such nonconformities, at its option, either by repairing any defective part or parts or by supplying a repaired or replacement part or parts F.O.B. factory. However, if Powercon has installed the equipment or furnished field engineering services with respect to its installation, and provided such installation has not been delayed by the Purchaser, said one year shall run from the completion of the installation. The total warranty period shall not exceed 18 months from the date of shipment in any case.

In no event shall Powercon be responsible for providing working access to the defect, including the removal, disassembly, replacement or reinstallation of any equipment, materials or structures to the extent necessary to permit Powercon to perform its warranty obligations, or transportation costs to and from the Powercon factory to repair facility. The conditions of any tests shall be mutually agreed upon and Powercon shall be notified of, and may be present at, all tests that may be made.

**THE WARRANTIES SET FORTH IN THIS PROVISION ARE EXCLUSIVE AND IN LIEU OF ALL OTHER WARRANTIES WHETHER STATUTORY, EXPRESS OR IMPLIED (INCLUDING ALL WARRANTIES OF MERCHANTABILITY AND FITNESS FOR PARTICULAR PURPOSE AND ALL WARRANTIES ARISING FROM COURSE OF DEALING OR USAGE OF TRADE), EXCEPT OF TITLE AND AGAINST PATENT INFRINGEMENT.** The remedies provided above are the Purchaser's sole remedies for any failure of Powercon to comply with its obligations. Correction of any nonconformity in the manner and for the period of time provided above shall constitute complete fulfillment of all the liabilities of Powercon whether the claims of the Purchaser are based in contract, in tort (including negligence) or otherwise with respect to or arising out of the equipment furnished hereunder.

## WARRANTY IMPLEMENTATION AND CONDITIONS

On those occasions where service help is required, the Powercon Corporation should be notified at once through its Service Department. No charges or expenses should be incurred except as authorized by the Corporation in writing. Making unauthorized corrections or doing unauthorized work voids this Warranty and renders reimbursement impossible.

At times, the Powercon Corporation may request labor and/or material services from you. At our option we will provide competent supervision who will authorize such services by signing the Time Sheets of the people involved. No reimbursement can be made without signed Time Sheets.

The services rendered must be of the type and quality satisfactory to the Powercon Corporation, and we reserve the right to reject any and all such services.

The above in no way prejudices the right of the Powercon Corporation to correct, as stipulated in the Warranty, any problems that may occur in equipment manufactured by the Powercon Corporation.

## FOREWORD

The warranty associated with this equipment is fully described with its implementation on Page ii. It should be emphasized that unless approved by the Powercon Corporation no modification, alteration, change or correction should be undertaken without such express authority provided in writing.

This Instruction Book is furnished in "As is" condition. No warranties expressed or implied, including warranties of fitness for a particular purpose, or merchantability, or warranties arising from course of dealing or usage of trade are made regarding the information, recommendations, descriptions, and safety notations contained herein. In no way will Powercon be responsible to the user in contract, in tort (including negligence), strict liability or otherwise for any direct special, indirect, incidental, or consequential damage or loss whatsoever, including but not limited to damage or loss of use of equipment, plant, or power system, cost of capital, loss of profits or revenues, cost of replacement power, additional expenses in the use of existing power facilities, or claims against the user by its customer resulting from the use of information, recommendations, descriptions, and safety notations contained herein.

The information, recommendations, descriptions, and safety notations in this document are based on Powercon's experience and judgement in respect to all of the subject matter contained herein. This information must not be considered to be all inclusive or covering all contingencies.

### **WARNING QUALIFIED PERSONNEL ONLY**

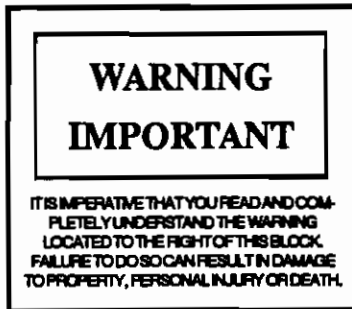

The equipment covered by this Instruction Book must be selected for a specific application and it must be installed, operated and maintained by qualified persons who are thoroughly trained and who understand all of the hazards involved. As with any electrical apparatus the thorough knowledge of the engineering safety, inspection, maintenance and repair techniques and familiarity with particular features of the apparatus involved is mandatory. This book does not provide sufficient instructions for inexperienced electricians or unqualified persons to do any work required including the handling, installation, testing, operation, inspection, maintenance, and repair.

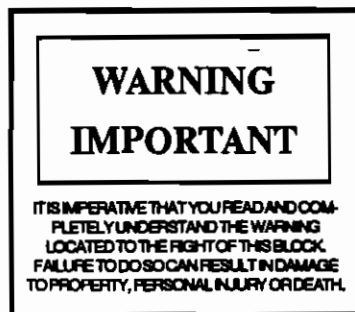

### **WARNING SAFETY GROUNDING**

#### **TO BE DONE ON DE-ENERGIZED EQUIPMENT ONLY**

Before energizing the equipment and prior to any testing it is recommended that all circuits be safely grounded. Prior to any grounding whether it be for any testing, inspection, or maintenance procedures, assure that all safety precautions are taken. It is further recommended that an appropriate properly operating glow tube instrument that lights up and warns the worker when held in any alternating current field, indicating the presence of voltage, be used prior to grounding

**Personnel doing such work should wear lineman's protective equipment in accordance with such equipment manufacturer's recommendations including but not limited to protective gloves, insulated sleeves, lineman's blankets, insulated helmets, face and eye protection that will assist in preventing injury if for any reason the equipment is grounded to an energized circuit. Every precaution should be taken to prevent electrical grounding on an energized circuit. Suitable grounding clamp leads should be used and safety grounding techniques employed. All such grounds must be removed after testing, inspection, or maintenance prior to energizing the equipment.**

The above in no way replaces the user's safety techniques or applicable safety codes, rules, or regulations.

# PIF DISCONNECT SWITCH MOTOR DRIVE

## INTRODUCTION

This book contains instructions for installation, operation, and maintenance of the Motor Drive System for a Powercon Interrupter Frame Mounted Switch. It should be read carefully before installation and initial operation of the equipment.

Separate publications will be supplied for other devices not described in this publication.

In addition to instruction books, the following drawings will be supplied.

1. Drawings which show the general arrangement, recommended space, mounting, etc.
2. Summary of Equipment which is a partial parts list, giving catalog numbers of all devices, etc.
3. When required:
  - (a). Control Wiring Diagram
  - (b). Elementary or Schematic Wiring Diagrams.

All of these documents are needed for installation, operation, and maintenance of equipment.

## RECEIVING, STORAGE AND HANDLING

### Receiving

Upon receipt of the equipment, immediately make an examination for any damage or loss sustained in shipment. This pertains to all devices and mechanisms. If injury, loss, or rough handling is evident, a written damage claim should be filed at once with the transportation company and the Powercon Corporation should be notified at the same time.

Be sure that no loose parts are left in the packaging material. Blow out any dirt or loose particles of packing material on or around the load break interrupter switch motor operator.

### Storage

When the unit is not to be placed in service immediately, it should be covered with a suitable cover. Moisture absorbing material should not be used to cover the equipment as it could cause corrosion of parts. Any temporary covering should not restrict ventilation and should not be removed until the equipment is ready for installation. 50 watt heaters should be placed in each unit to prevent moisture damage.

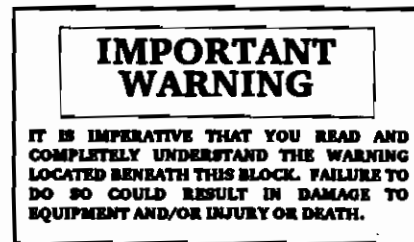

### **CAUTION**

**REMOVE ALL FLAMMABLE MATERIAL  
AWAY FROM HEATERS PRIOR TO  
ENERGIZING.**

During the construction period it should be properly protected against construction environment conditions such as moisture, dirt, cement, rough handling, abrasion, damage, etc.

If equipment has been subjected to moisture, it should be tested with a 1000V megger. A reading of 200 megohms should be obtained.

Study the erection drawing carefully and check the bill of material to be sure that all parts are at hand.

## DESCRIPTION

The Powercon Motor Operator utilizes a powerful direct drive motor assembly to charge the latching spring mechanism which opens and closes the interrupter switch, not the electric drive. **Due to the high level of torque generated by this drive assembly, please read all instructions and carefully follow the sequence to prevent**

physical damage to the drive unit, interrupter switch, or cubicle. If after reading these instructions you still have questions, please contact the Powercon Corporation prior to beginning this procedure.

The sequence of operation as outlined in this instruction book is based on a "Typical" Motor Operated Drive Assembly as shown on the drawings in this book. Based on particular application requirements there may be internal control modifications not shown in the "typical" operation sequence. The terminal designations for the major components such as the microswitches, motor, reversing contactor, etc. are standard with Powercon and should not change. Please compare the standard drawing for the appropriate control voltage with the wiring schematic shipped with the Motor Operator. This should be done prior to beginning any work.

The switch handle is retained by a key lock containing a microswitch. Placing the handle in the lock and rotating the key prevents removing both handle and key. The microswitch is then closed to complete the motor control power circuit.

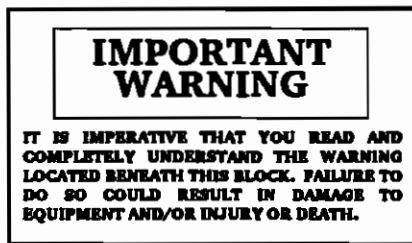

**CAUTION**

**DO NOT ATTEMPT TO BYPASS THE MICROSWITCH BY REMOVING THE HANDLE AND PLACING IT IN THE OPERATING MECHANISM. TO DO SO WILL ALLOW THE MOTOR TO OPERATE, ROTATING THE HANDLE AND SERIOUS INJURY COULD OCCUR.**

**CAUTION**

**DO NOT OPERATE UNTIL ALL ADJUSTMENTS ARE COMPLETE AS DESCRIBED IN SECTION ENTITLED "ADJUSTMENTS".**

**OPERATION**

This drive system consists of:

- 1. Heavy Duty Universal Gear Motor (M)
- 2. Full-Wave Bridge Rectifier (RECT)
- 3. Double-throw Contactor 3-Pole or 4-Pole (89-XY)
- 4. Industrial Solenoid (SOL)
- 5. Clutch and Spring Mechanism Coupled to the Drive Motor (CL & SP)
- 6. PIF Auxiliary Cam Switch, Chain Driven Normally Open (89/OP) Normally Closed (89/CL)

The simplicity of this drive system is best demonstrated by the Kinematic Diagram (Figure 1).

When the main interrupter (89) is signaled to operate (close), the 89-X coil (Figure 2) is energized, closing all of its contacts and mechanically blocking 89Y from being energized. Solenoid (SOL) is then energized.

Movement of the solenoid (SOL) [Figure 3] compresses spring (SP) and engages clutch (CL). Motor rotates sprocket (SRA) which through its chain drive (CHA) rotates the PIF drive shaft to close the load break switch.

When the PIF drive shaft rotates overcenter, auxiliary switch (89-OP/CL) reverses its position, de-energizing the closing relay (89X) to:

- 1. Stop the motor (A)
- 2. De-energize solenoid (SOL)
- 3. Sets-up PIF opening circuits.

De-energizing solenoid (SOL) releases compressed springs (SP) energy to disengage the clutch (CL). Disengagement of the clutch is to prevent the motor armature inertia from overdriving the PIF drive shaft and causing mechanical damage.

To open the PIF apply a signal to the 89-Y coil. The PIF will open in the same manner as described above and set-up the control circuit for a closing signal.

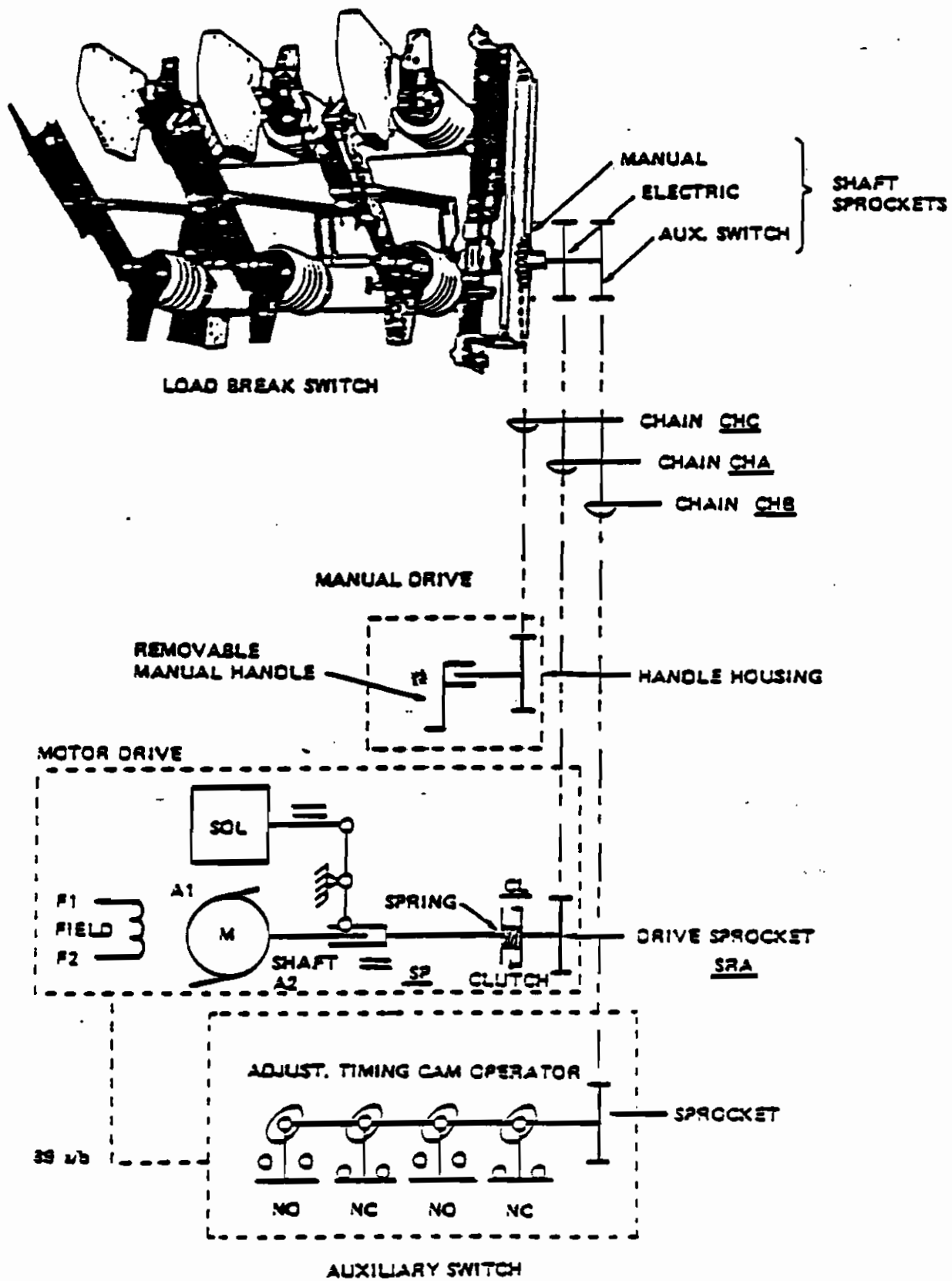
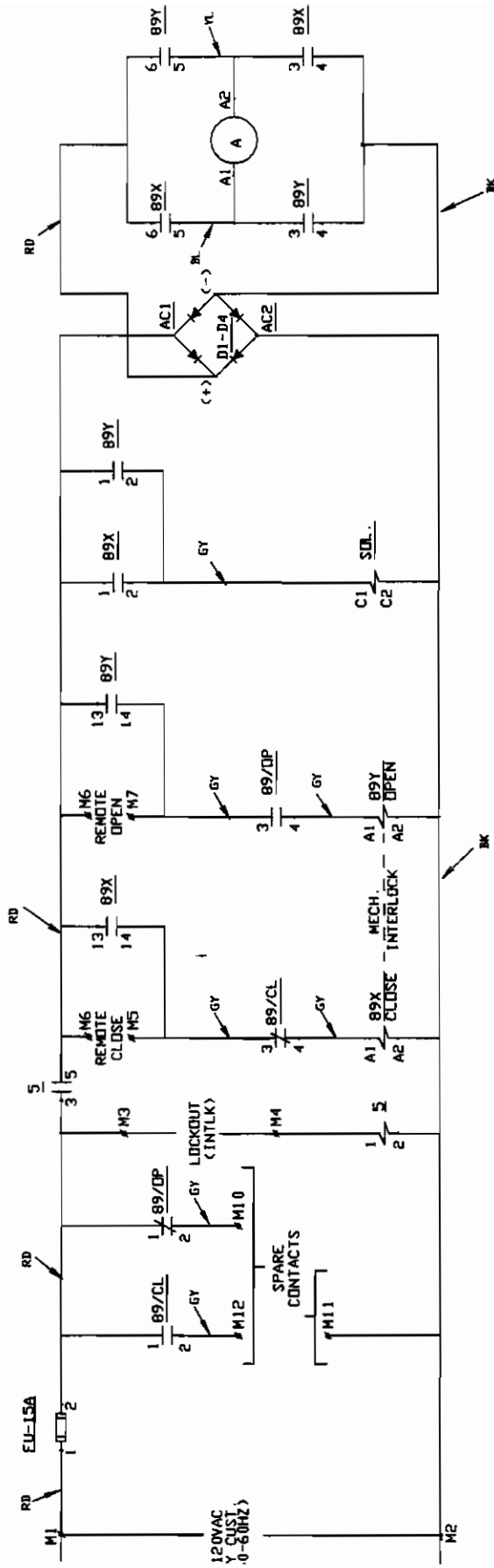

Figure 1. Motor Drive System Kinematic Diagram





**TYPICAL CONTROL DIAGRAM**

1. Follow all safety instructions outlined in PCIB-1008 (latest edition).
  2. If alternating current is used as the control power source, a full wave bridge rectifier circuit is utilized to polarize the voltage placed across the motor armature. This allows the reversal of the motor depending upon the polarity of voltage applied to the armature.
  3. Refer to Figures 1, 3 and 4.
  4. For Description of Typical Operation see Page 5. For actual operation refer to drawings.
5. The device numbers used in the Schematic Diagram are from the American National Standards Institute and descriptions are as follows:
- |       |   |
|-------|---|
| 5     | Stopping Device                                 |
| 89    | Line Switch                                     |
| 89X   | Closing Relay                                   |
| 89Y   | Opening Relay                                   |
| 89/CL | Auxiliary Switch on 89 (Closed when 89 is Open) |
| 89/OP | Auxiliary Switch on 89 (Open when 89 is Open)   |
| SOL   | Clutch Solenoid                                 |
| A     | Motor Armature                                  |
| FS    | Fuse  |
| D1-D4 | Diode Bridge (Omitted when control power is DC) |

**Figure 2.**

To reverse from either a closing or opening operation, the polarity of the motor armature is reversed.

Removal of the manual handle from its storage position de-energizes the motor drive circuit.

Decoupling test feature (optional) if required to test motor drive system without moving main switch blades can be accomplished by inserting a control switch in series with the solenoid (SOL) or simply removing decoupling jumper. (Schematic Diagram, Figure 2).

### CAUTION

**DO NOT LEAVE EQUIPMENT IN DECOUPLED MODE. IF LEFT IN THAT MODE A SIGNAL TO OPERATE WILL CONTINUOUSLY DRIVE MOTOR WITHOUT OPERATING PIF SWITCH BLADES.**

## **SEQUENCE OF OPERATION**

(For Exact Wiring and Operation Refer to Drawings Furnished with Equipment)

(Typical)

Apply the proper control voltage to terminals M1 and M2.

### CAUTION

**It is essential that the incoming POSITIVE be connected to the POSITIVE terminal of the drive controls and the NEGATIVE be connected to the NEGATIVE of the drive system. Severe damage will be caused if these polarities are reversed.**

### **TO CLOSE THE SWITCH:**

1. a. Return manual handle to the cradle.  
b. Turn cradle keylock to capture the key and close its auxiliary contact.  
c. Make sure any remote lockout devices in series with the cradle lock switch are closed. Terminals M3-M4 are for this key interlock system.
2. Relay 5 is energized to close the 3-5 contacts and energize the control power bus.
3. Complete the circuits of M5 and M6 with a momentary closing contact.
4. 89X circuit is energized through the normally closed 89/CL contact 3-4.
5. The 89X contacts 13-14 seal around the remote-close contacts. (Note: 89X-89Y relays are mechanically interlocked to prevent both being closed at the same time).
6. Contacts 1-2 of 89X is closed to energize the clutch solenoid (SOL).
7. Also contact 5-6 and 3-4 of 89X close placing the positive DC voltage on motor armature terminal A1.

The motor rotates then to close switch 89.

8. The closing of switch 89 reverses its auxiliary switch 89/CL to open and auxiliary switch 89/OP to close setting up the opening circuit of 89 upon receipt of an opening signal to terminals M6-M7.
9. The opening of 89/CL drops out 89X thereby breaking the seal in contact 89X-13-14. Also the motor is de-energized by opening the 89X contacts.

### **TO OPEN THE SWITCH**

10. In the same manner a remote-open signal placed on terminals M6-M7 will energize 89Y to:
  - a. Energize clutch solenoid (SOL).
  - b. Place positive DC on armature terminal A2 to reverse motor direction.
11. Once 89 is closed 89/OP opens to de-energize SOL, stop motor, and 89/CL closes to set up the next closing operation. All as described above.

## **ADJUSTMENTS**

**(Refer to Figures 3 and 4)**

### **1. Wiring Harness Inspection**

Refer to the Wiring Diagram and Schematic shipped with the Operator Pan Assembly trace out all inter-wiring connections insuring conformity with the diagram and to insure understanding of all remote interconnect requirements.

### **2. Deactivate the Direct Drive Solenoid Conpler Assembly**

Disconnect the coil wiring on the direct drive solenoid. This is done by disconnecting the three (3) black wires and one (1) grey wire hooked up to Terminal 2 and Terminal 1 respectively on the coil itself. (See Wiring Diagram).

Isolate the black lead wire from the coil and make sure this wire is isolated and insulated from any power source. Take the remaining two (2) black wires, which if traced back go to wiring points A2 and AC2, and verify they are jumpered together allowing power to flow to the D1-D4 bridge.

Insulate and isolate the grey wire disconnected from Point 1 on the solenoid coil.

### **3. Checking Motor Rotation**

Hook up your remote close and remote open devices. Energize with the required control voltages. Now check the directional rotation of shaft. The top of the shaft should spin in the same direction as the intended interrupter switch motion. To test, jumper lockout interlock provision at the M3-M4 terminal connection.

Now activate the remote close device. The top of the shaft should be spinning toward the interrupter switch. Now activate the remote open device. The top of the shaft should be spinning toward the front of the cubicle. If this rotation is not correct reverse the power leads to the motor to reverse polarity and therefore reverse rotation of the shaft.

### **4. Cam Adjustment**

Make adjustments with all control power off.

Loosen the cam set screws, flush with the cam sur-

face. The cams should hang freely. Using the manual handle, operate the interrupter switch to the closed position, roll the BG cam in the direction of the switch motion to close and set the cam 1/8" past the BG microswitch "click".

Using the manual handle, operate the interrupter switch to the open position, roll the BJ cam in the direction of the switch motion to open and set the cam 1/8" past the BJ microswitch "click".

**NOTE:** When the interrupter switch has a "quick-trip" feature the BK cam must be adjusted.

With the switch in the "quick-trip" position, rotate the BK cam until the high point compresses the microswitch and the contact "clicks".

### **5. Verify Cam Adjustment**

Verify the direct drive solenoid coil is disconnected. Energize control power. Initiate the electrical operator. When the motor starts to run:

- a. Verify motor rotation.
- b. Using the manual handle, throw the switch manually. The motor should be stopped when the primary switch has operated.
- c. Repeat this procedure in both directions.

Fine cam adjustment may be required until the above operation is satisfactory.

### **Remember**

**The motor operator is designed to charge the spring assembly and travel the operator assembly only to the point where the spring loaded mechanism opens or closes the interrupter switch.**

**THE MOTOR DRIVE DOES NOT PHYSICALLY OPEN OR CLOSE THE SWITCH CONTACTS ITSELF.**

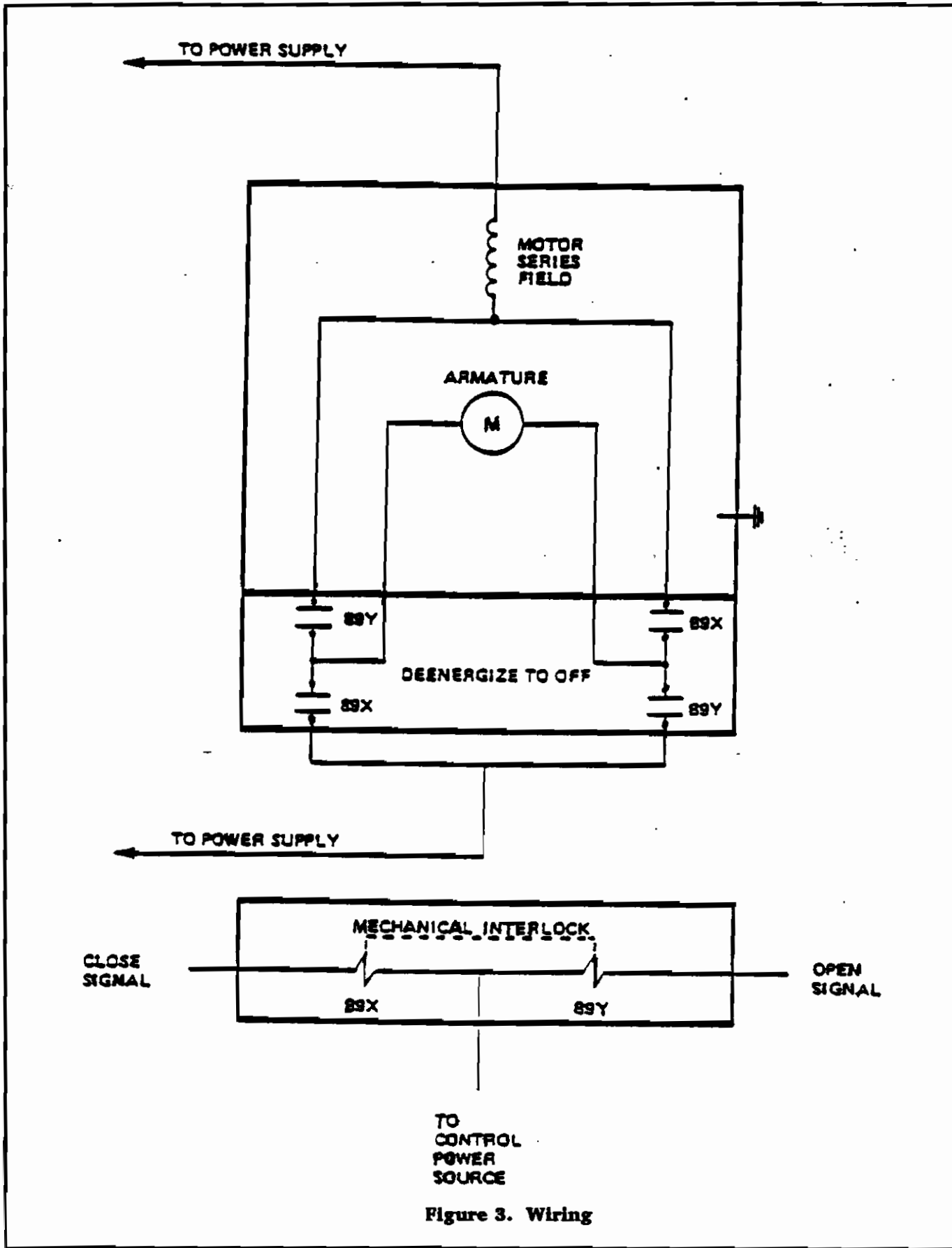
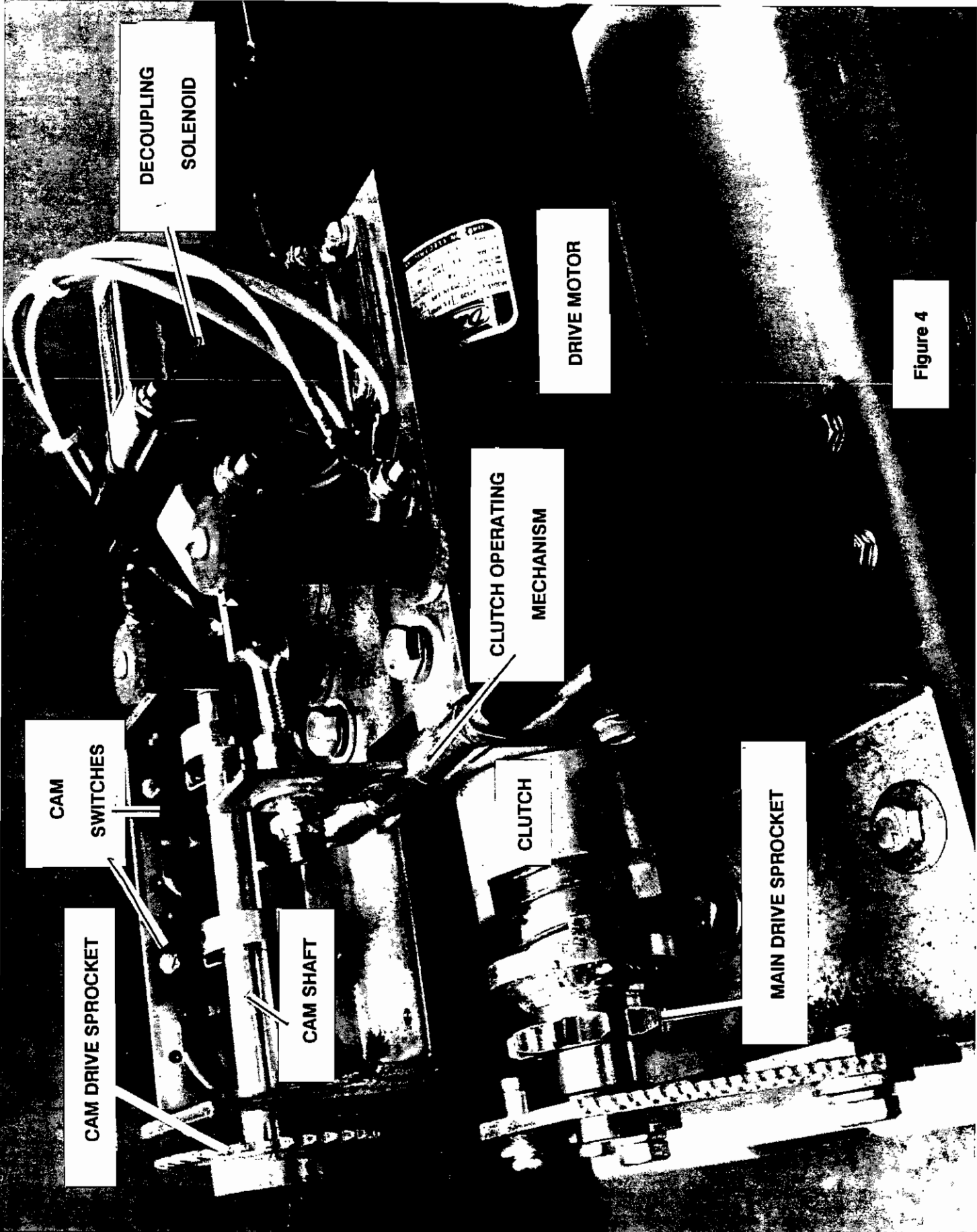

Figure 3. Wiring



DECOUPLING  
SOLENOID

DRIVE MOTOR

CLUTCH OPERATING  
MECHANISM

Figure 4

CAM  
SWITCHES

CAM DRIVE SPROCKET

CAM SHAFT

CLUTCH

MAIN DRIVE SPROCKET

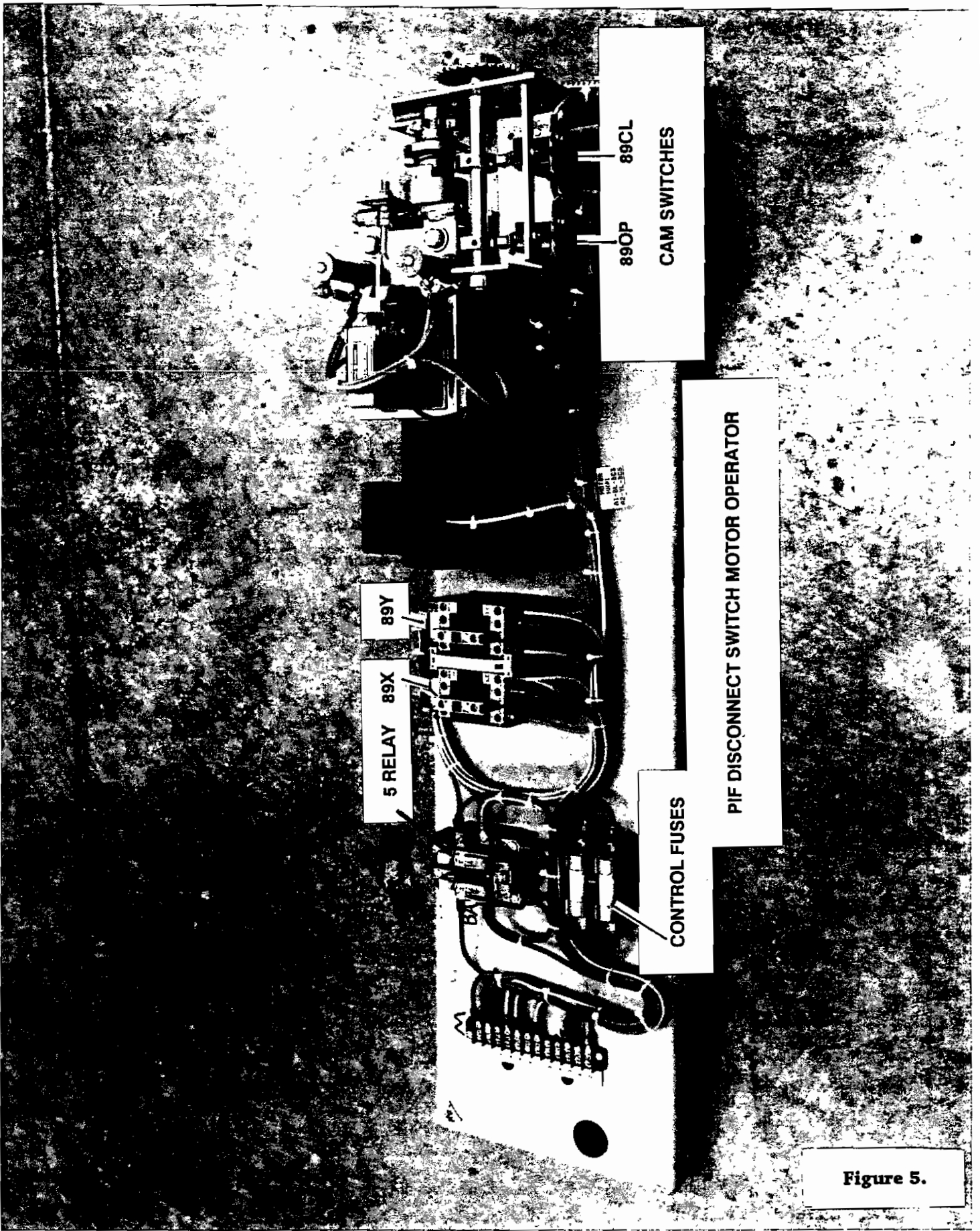

**Figure 5.**

After you have followed Points 1 through 5, you are ready to test the electric motor operator utilizing the Direct Drive Motor Assembly. Simply remove the lock out interlock jumper at Terminals M3 and M4. Reconnect the coil wiring at the solenoid. Then remove and store the manual handle in its designated area. Now you will be ready to activate the motor drive through remote devices.

If you find the motor operator cutting off prior to the spring mechanism discharging in the intended direction, adjust the particular cam and microswitch position

so as to let the motor operator drive forward *slightly* longer. If you find the operator overdriving, adjust the cam to cut the motor drive off earlier.

If Steps 4 and 5 are properly followed, there should be no need for adjustment under an electric operation.

Again, the importance is stressed of properly setting the cams prior to testing in the coupled position with the motor drive assembly. Incorrect setting will cause damage. Please call the Powercon Corporation if you have any questions.

## SPARE PARTS

For Spare Parts - Refer to Nameplate and identify parts as described on pages 8 and 9.

## INSPECTION AND MAINTENANCE

<u>Control Circuit Parts</u>			
<i>Inspection Item</i>	<i>Criteria</i>	<i>Inspection Method</i>	<i>Corrective Action</i> <i>(If necessary)</i>
Closing and opening devices including disconnects.	Smooth and correct operation by control power.	Test closing and opening of the switch twice.	Replace any defective device.
Wiring	Securely tied in proper place.	Visual check.	Repair or tie as necessary.
Terminals	Tight	Visual check.	Tighten or replace if necessary.
<u>Operating Mechanism</u>			
<i>Inspection Item</i>	<i>Criteria</i>	<i>Inspection Method</i>	<i>Corrective Action</i> <i>(If necessary)</i>
Motor	5000 Operations	Check condition.	Replace brushes.
Tightness of hardware	No loose or missing parts.	Visual and tightening with appropriate tools.	Tighten or reinstate if necessary.
Dust or foreign matter	No dust or foreign matter	Visual check	Clean as necessary
Lubrication	Smooth operation and no excessive wear.	Sight and feel	Lubricate very sparingly with light machine oil.
Deformation or excessive wear	No excessive deformation or wear.	Visual and operational.	Remove cause and replace parts.
Manual operation	Smooth and crisp operation.	Manual closing and opening.	Correct if necessary

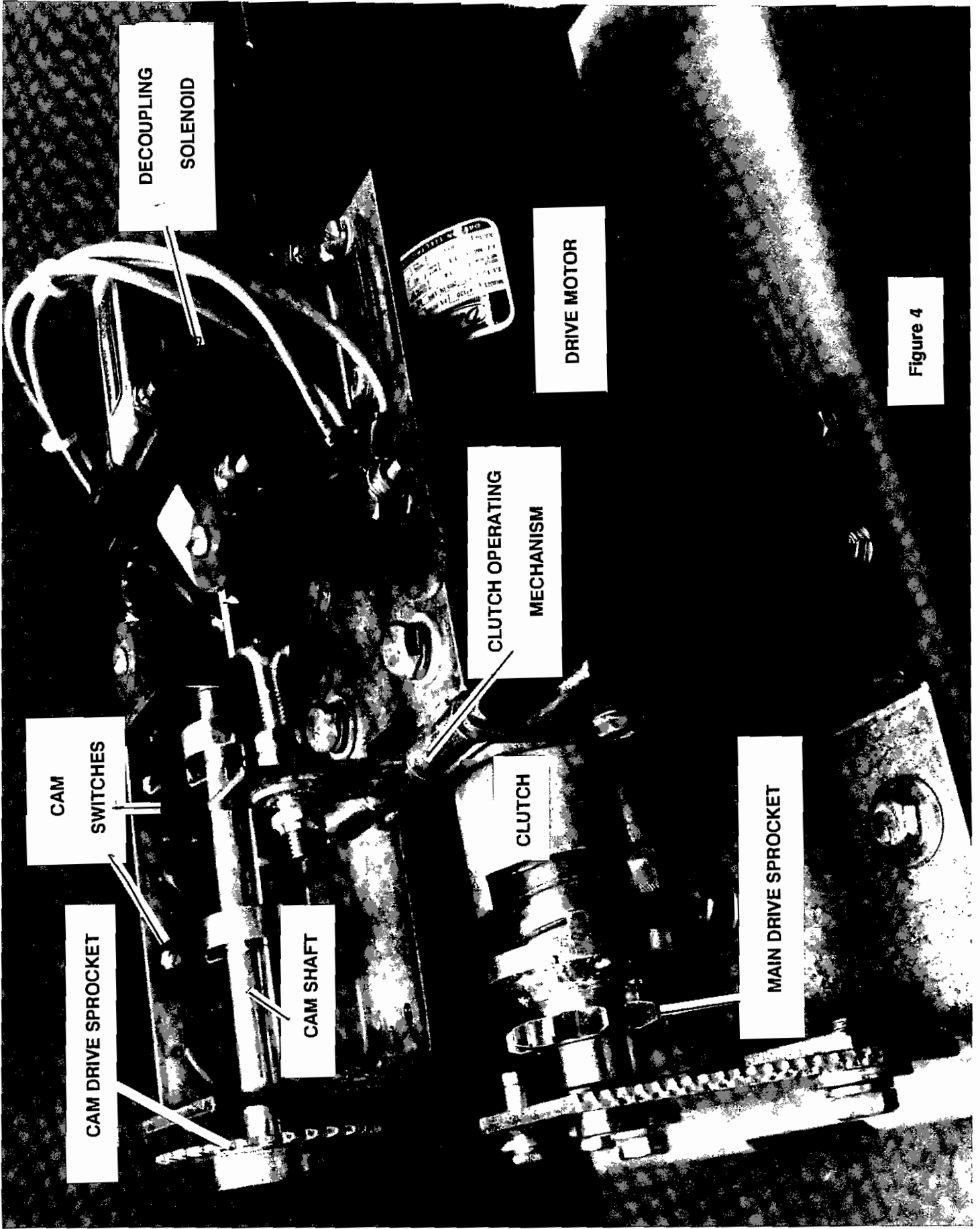

DECOUPLING  
SOLENOID

DRIVE MOTOR

CLUTCH OPERATING  
MECHANISM

Figure 4

CAM  
SWITCHEs

CAM DRIVE SPROCKET

CAM SHAFT

CLUTCH

MAIN DRIVE SPROCKET



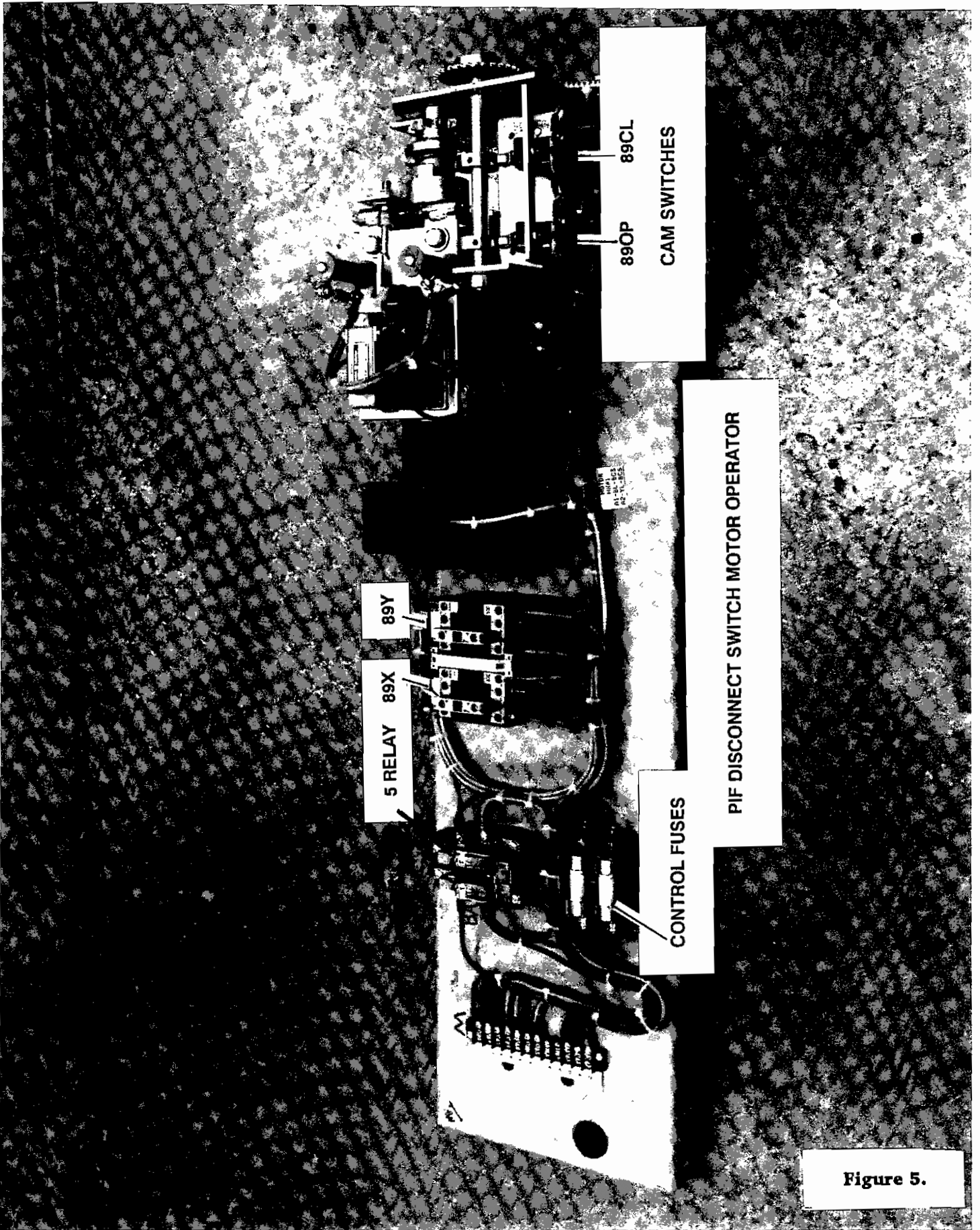

**Figure 5.**

After you have followed Points 1 through 5, you are ready to test the electric motor operator utilizing the Direct Drive Motor Assembly. Simply remove the lock out interlock jumper at Terminals M3 and M4. Reconnect the coil wiring at the solenoid. Then remove and store the manual handle in its designated area. Now you will be ready to activate the motor drive through remote devices.

If you find the motor operator cutting off prior to the spring mechanism discharging in the intended direction, adjust the particular cam and microswitch position

so as to let the motor operator drive forward *slightly* longer. If you find the operator overdriving, adjust the cam to cut the motor drive off earlier.

If Steps 4 and 5 are properly followed, there should be no need for adjustment under an electric operation.

Again, the importance is stressed of properly setting the cams prior to testing in the coupled position with the motor drive assembly. Incorrect setting will cause damage. Please call the Powercon Corporation if you have any questions.

## SPARE PARTS

For Spare Parts - Refer to Nameplate and identify parts as described on pages 8 and 9.

## INSPECTION AND MAINTENANCE

<u>Control Circuit Parts</u>			
<i>Inspection Item</i>	<i>Criteria</i>	<i>Inspection Method</i>	<i>Corrective Action</i> <i>(if necessary)</i>
Closing and opening devices including disconnects.	Smooth and correct operation by control power.	Test closing and opening of the switch twice.	Replace any defective device.
Wiring	Securely tied in proper place.	Visual check.	Repair or tie as necessary.
Terminals	Tight	Visual check.	Tighten or replace if necessary.
<u>Operating Mechanism</u>			
<i>Inspection Item</i>	<i>Criteria</i>	<i>Inspection Method</i>	<i>Corrective Action</i> <i>(if necessary)</i>
Motor	5000 Operations	Check condition.	Replace brushes.
Tightness of hardware	No loose or missing parts.	Visual and tightening with appropriate tools.	Tighten or reinstate if necessary.
Dust or foreign matter	No dust or foreign matter	Visual check	Clean as necessary
Lubrication	Smooth operation and no excessive wear.	Sight and feel	Lubricate very sparingly with light machine oil.
Deformation or excessive wear	No excessive deformation or wear.	Visual and operational.	Remove cause and replace parts.
Manual operation	Smooth and crisp operation.	Manual closing and opening.	Correct if necessary