

**INSTRUCTION BOOK**

**MICRO-RUPTER  
Frame Mounted  
LOAD BREAK INTERRUPTER SWITCH**

**NOMINAL RATINGS:  
2.4/4/16kV 200A and 400A    7.2kV 200A and 400A**

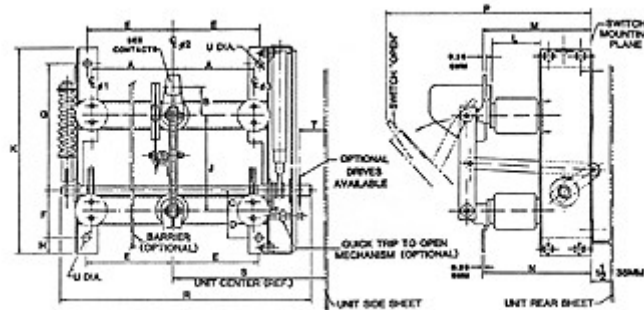

**WARNING**

**FOLLOW THE SAFETY INSTRUCTIONS AND WARNINGS  
THROUGHOUT THIS BOOK. FAILURE TO DO SO  
CAN RESULT IN DAMAGE TO PROPERTY, PERSONAL INJURY, OR DEATH.**

**IN ADDITION TO THE MAINTENANCE AND PRECAUTIONS  
AS OUTLINED WITHIN, REFER TO ANSI Z244.1-1982 ENTITLED:  
LOCKOUT/TAGOUT OF ENERGY SOURCES MINIMUM SAFETY REQUIREMENTS**

\*\*\*\*\*

**These instructions may not cover all details or variations in equipment, nor provide for every possible contingency encountered. Should further information be desired or should problems arise which are not covered sufficiently, the matter should be referred to the POWERCON CORPORATION**

P.O. Box 477, 1551 Florida Avenue, Severn, MD 21144 Phone: 410-551-6500 email info@powerconcorp.com

**WARNING  
IMPORTANT**

IT IS IMPERATIVE THAT YOU READ AND COMPLETELY UNDERSTAND THE WARNING LOCATED TO THE RIGHT OF THIS BLOCK, FAILURE TO DO SO CAN RESULT IN DAMAGE TO PROPERTY, PERSONAL INJURY OR DEATH



DO NOT REMOVE COVERS, OPEN DOORS, OR WORK ON EQUIPMENT UNLESS POWER HAS BEEN TURNED OFF AND ALL CIRCUITS DE-ENERGIZED AND DISCONNECTED. DISCONNECT, DE-ENERGIZE, LOCKOUT AND PROPERLY GROUND CIRCUIT(S) BEFORE WORKING ON THIS EQUIPMENT. USE PROPER SAFETY PRECAUTIONS WHEN WORKING ON THIS EQUIPMENT.

ALL SAFETY CODES, SAFETY STANDARDS, AND/OR REGULATIONS AS THEY MAY BE APPLIED TO THIS TYPE OF EQUIPMENT MUST BE STRICTLY ADHERED TO. BEFORE ANY ADJUSTMENTS, SERVICING, PARTS REPLACEMENT OR ANY OTHER ACT IS PERFORMED REQUIRING ANY PHYSICAL CONTACT WITH THE ELECTRICAL COMPONENTS OR WIRING OF THIS EQUIPMENT, THE POWER SUPPLY MUST BE DISCONNECTED.



IN ADDITION TO THE PERSONNEL PRECAUTIONS AS OUTLINED, REFER TO:

- Z244.1-1982 PERSONNEL PROTECTION LOCKOUT/TAGOUT OF ENERGY SOURCES MINIMUM SAFETY REQUIREMENTS
- ANSI/NFPA 70E-1988: ELECTRICAL SAFETY REQUIREMENTS FOR EMPLOYEE WORKPLACES
- ANSI/NFPA 70B-1988: ELECTRICAL EQUIPMENT MAINTENANCE



THE EQUIPMENT COVERED BY THIS INSTRUCTION BOOK MUST BE SELECTED FOR A SPECIFIC APPLICATIONS AND IT MUST BE INSTALLED, OPERATED, AND MAINTAINED BY QUALIFIED PERSONS WHO ARE THOROUGHLY TRAINED AND WHO UNDERSTAND ALL OF THE HAZARDS INVOLVED. As with any electrical apparatus, the thorough knowledge of the engineering safety, inspection, maintenance and repair techniques as well as being familiar with particular features of the apparatus involved is mandatory. THIS BOOK DOES NOT PROVIDE SUFFICIENT INSTRUCTIONS FOR INEXPERIENCED ELECTRICIANS OR UNQUALIFIED PERSONS TO DO ANY WORK REQUIRED INCLUDING THE HANDLING, INSTALLATION, TESTING, OPERATION, INSPECTION, MAINTENANCE, AND REPAIR.



BEFORE CHECKING OR MAINTENANCE OF SWITCHGEAR, AFTER IT HAS BEEN INSTALLED - THE FOLLOWING MUST BE OBSERVED: ONLY QUALIFIED PERSONS MAY OPERATE, INSPECT OR MAINTAIN POWER SWITCHGEAR. IN ADDITION TO THE PERSONNEL YOU MAY HAVE WHO ARE QUALIFIED, OTHERS MAY BE AVAILABLE FROM AN EXPERIENCED HIGH VOLTAGE CONTRACTOR OR THE UTILITY SERVICING THE INSTALLATION. IT IS THE RESPONSIBILITY OF THE PURCHASER, INSTALLER, OR ULTIMATE USER TO INSURE THAT THE WARNING SIGNS ARE NOT REMOVED AND TO MAKE SURE THAT ALL ACCESS DOORS, AND OPERATING HANDLES ARE SECURELY LOCKED WHEN THE GEAR IS LEFT UNATTENDED BY QUALIFIED PERSONS, EVEN MOMENTARILY.



SAFETY GROUNDING TO BE DONE ON DE-ENERGIZED EQUIPMENT ONLY.

Before energizing the equipment and prior to any testing it is recommended that all circuits be safely grounded. Prior to any grounding whether it be for any testing, inspection, or maintenance procedures, assure that all safety precautions are taken. It is further recommended that an appropriate properly operating glow tube instrument that lights up and warns the worker when held in any alternating current field, indicating the presence of voltage, be used prior to grounding.

PERSONNEL DOING SUCH WORK SHOULD WEAR LINEMAN'S PROTECTIVE EQUIPMENT IN ACCORDANCE WITH SUCH EQUIPMENT MANUFACTURER'S RECOMMENDATIONS INCLUDING BUT NOT LIMITED TO PROTECTIVE GLOVES, INSULATED SLEEVES, LINEMAN'S BLANKETS, INSULATED HELMETS, FACE AND EYE PROTECTION that will assist in preventing injury if for any reason the equipment is grounded to an energized circuit. Every precaution should be taken to prevent electrical grounding on an energized circuit. Suitable grounding clamp leads should be used and safety grounding techniques employed. ALL SUCH GROUNDS MUST BE REMOVED AFTER TESTING, INSPECTION, OR MAINTENANCE PRIOR TO ENERGIZING THE EQUIPMENT.

In as much as Powercon has no control over the use to which others may put this material, statements concerning uses of the materials described herein are not to be construed as suitable for these used unless proper technology in the usage, applications, and maintenance are strictly observed. For further information call or write the Powercon Corporation.



**LIMITED WARRANTY**

Powercon warrants that the equipment we deliver will be of the kind and quality described in the order or contract and will be free of defects in workmanship and material. Should any failure to conform to this warranty appear within one year after date of shipment, Powercon shall upon prompt notification thereof and substantiation that the equipment has been stored, installed, operated and maintained in accordance with Powercon recommendations and standard industry practice, correct such nonconformities, at its option, either by repairing any defective part or parts or by supplying a repaired or replacement part or parts F.O.B. factory. However, if Powercon has installed the equipment or furnished field engineering services with respect to its installation, and provided such installation has not been delayed by the Purchaser, said one year shall run from the completion of the installation. The total warranty period shall not exceed 18 months from the date of shipment in any case.

In no event shall Powercon be responsible for providing working access to the defect, including the removal, disassembly, replacement or reinstallation of any equipment material or structures to the extent necessary to permit Powercon to perform its warranty obligations, or transportation costs to and from the Powercon factory or repair facility. The conditions of any tests shall be mutually agreed upon and Powercon shall be notified of, and may be present at, all tests that may be made.

**THE WARRANTIES SET FORTH IN THIS PROVISION ARE EXCLUSIVE AND IN LIEU OF ALL OTHER WARRANTIES WHETHER STATUTORY, EXPRESS OR IMPLIED (INCLUDING ALL WARRANTIES OF MERCHANTABILITY AND FITNESS FOR PARTICULAR PURPOSE AND ALL WARRANTIES ARISING FROM COURSE OF DEALING OR USAGE OF TRADE), EXCEPT OF TITLE AND AGAINST PATENT INFRINGEMENT.** The remedies provided above are the purchaser's sole remedies for any failure of Powercon to comply with its obligations. Correction of any nonconformity in the manner and for the period of time provided above shall constitute complete fulfillment of all the liabilities of Powercon whether the claims of the Purchaser are based in contract, in tort (including negligence) or otherwise with respect to or arising out of the equipment furnished hereunder.

**WARRANTY IMPLEMENTATIONS AND CONDITIONS**

On those occasions where service help is required, the Powercon Corporation should be notified at once through its Service Department. No charges or expenses should be incurred except as authorized by the Corporation in writing. Making unauthorized corrections or doing unauthorized work voids this Warranty and renders reimbursement impossible.

At times, the Powercon Corporation may request labor and/or material services from you. At our option we will provide competent supervision who will authorize such services by signing the Time Sheets of the people involved. No reimbursement can be made without signed Time Sheets.

The services rendered must be of the type and quality satisfactory to the Powercon Corporation, and we reserve the right to reject any and all such services.

The above in no way prejudices the right of the Powercon Corporation to correct, as stipulated in the Warranty, any problems that may occur in equipment manufactured by the Powercon Corporation.

## FOREWORD

The warranty associated with this equipment is fully described with its implementation on Page i. It should be emphasized that unless approved by the Powercon Corporation no modification, alteration, change or correction should be undertaken without such express authority provided in writing by an authorized Powercon representative.

This Instruction Book is furnished in "As is" condition. No warranties expressed or implied, including warranties of fitness for a particular purpose, or merchantability, or warranties arising from course of dealing or usage of trade are made regarding the information, recommendations, descriptions, and safety notations contained herein. In no way will Powercon be responsible to the user in contract, in tort (including negligence), strict liability or otherwise for any direct special, indirect, incidental, or consequential damage or loss whatsoever, including but not limited to damage or loss of use of equipment, plant, or power system, cost of capital, loss of profits or revenues, cost of replacement power, additional expenses in the use of existing power facilities, or claims against the user by its customer resulting from the use of information, recommendations, descriptions, and safety notations contained herein.

The information, recommendations, descriptions, and safety notations in this document are based on Powercon's experience and judgment in respect to all of the subject matter contained herein. This information must not be considered to be all inclusive or covering all contingencies.

### WARNING IMPORTANT

IT IS IMPERATIVE THAT YOU READ AND COMPLETELY UNDERSTAND THE WARNING LOCATED TO THE RIGHT OF THIS BLOCK, FAILURE TO DO SO CAN RESULT IN DAMAGE TO PROPERTY, PERSONAL INJURY OR DEATH

### WARNING IMPORTANT

IT IS IMPERATIVE THAT YOU READ AND COMPLETELY UNDERSTAND THE WARNING LOCATED TO THE RIGHT OF THIS BLOCK, FAILURE TO DO SO CAN RESULT IN DAMAGE TO PROPERTY, PERSONAL INJURY OR DEATH

### QUALIFIED PERSONNEL ONLY

The equipment covered by this Instruction Book must be selected for a specific application and it must be installed, operated and maintained by qualified persons who are thoroughly trained and who understand all of the hazards involved. As with any electrical apparatus the thorough knowledge of the engineering safety, inspection, maintenance and repair techniques and familiarity with particular features of the apparatus involved is mandatory. This book does not provide sufficient instructions for inexperienced electricians or unqualified persons to do any work required including the handling, installation, testing, operation, inspection, maintenance, and repair. Refer to OSHA 29CFR Part 1910.399 for definition of "qualified person".

### WARNING SAFETY GROUNDING TO BE DONE ON DE-ENERGIZED EQUIPMENT ONLY

Before energizing the equipment and prior to any testing or maintenance it is recommended that all circuits be safely grounded. Prior to any grounding whether it be for any testing, inspection, or maintenance procedures, assure that all safety precautions are taken. It is further recommended that an appropriate properly operating glow tube instrument that lights up and warns the worker when held in any alternating current field, indicating the presence of voltage, be used prior to grounding

Personnel doing such work should wear lineman's protective equipment in accordance with such equipment manufacturer's recommendations including but not limited to protective gloves, insulated sleeves, lineman's blankets, insulated helmets, face and eye protection that will assist in preventing injury if for any reason the equipment is grounded to an energized circuit. Every precaution should be taken to prevent electrical grounding on an energized circuit. Suitable grounding clamp leads should be used and safety grounding techniques employed. All such grounds must be removed after testing, inspection, or maintenance prior to energizing the equipment.

The above in no way replaces the user's safety techniques or applicable safety codes, rules, or regulations.

## APPLICATION

Micro-Rupter Load Break Interrupter Switches are applied in the control and switching of Power Distribution Systems having nominal A.C. voltage ratings of 2.4KV to 7.2KV. They are capable of switching 200 & 400 amperes.

**TABLE I** lists the applicable limits and conditions of switching. When used in conjunction with fuses they will afford overload, short circuit and disconnect services.

These switches are used:

1. On the primary of transformers for their protection and isolation.
2. For the protection and isolation of single circuit systems.
3. For the protection and isolation of multi-circuit systems.

**TABLE 1**

**MICRO-RUPTER AIR INTERRUPTER SWITCH RATINGS**

(These ratings apply to Switches & Equipments with Stored Energy Operated Switches)  
(Special Ratings Available - Consult Factory)

<b>VOLTAGE RATINGS, KV</b>		<b>CURRENT RATINGS</b>		
Max. Design	BIL	Continuous A	Contact Interrupt. A	Fault Close & Momentary KA
5.5	60	200	200	22.5
		400	400	22.5
8.25	95	200	200	22.5
		400	400	22.5

## **RECEIVING, HANDLING AND STORAGE**

Upon receipt of the load break interrupter switch or switchgear, immediately make an examination for any damage or loss sustained in shipment. This pertains to the housing as well as the load break switch and mechanism. If injury, loss or rough handling is evident, a written damage claim should be filed at once with the transportation company and the Powercon Corporation should be notified at the same time.

Be sure that no loose parts are left in the packaging material. Blow out any dirt or loose particles of packing material on or around the load break switch and mechanism.

When the unit is not to be placed in service immediately, it should be stored in a clean, dry location and covered with a suitable cover. Moisture absorbing material should not be used to cover the equipment, as that could cause corrosion of parts.

During the construction period it should be properly protected against construction environment conditions such as moisture, dirt, cement, rough handling, abrasion, damage, etc..

When dampness or condensation exists, the equipment must be covered with a suitable vented cover to allow moisture to escape. Heaters of 250 watts rating should be placed in each unit to prevent moisture damage. **CAUTION: REMOVE ALL FLAMMABLE MATERIALS AWAY FROM HEATERS PRIOR TO ENERGIZING.**

**IF EQUIPMENT HAS BEEN SUBJECTED TO MOISTURE, IT SHOULD BE TESTED WITH A 1000V MEGGER. A READING OF 200 MEGOHMS SHOULD BE OBTAINED.**

Study the erection drawing carefully and check the bill of material to be sure that all parts are at hand.

The shipment should include:

1. Three-pole interrupter switch, factory-assembled on a rugged base of welded construction.
2. Interphase barriers and side barriers as required.
3. Operating handle.
4. The appropriate set of operating-mechanism components required for the specific installation including chain, handle, etc..

Before taking the switch from its shipping crate, remove the insulating barriers\* and set them aside to prevent their being damaged. Barriers are to be attached to the switch only after all other assembly operations are complete and adjustments are satisfactory. Remove also the operating handle mechanism components. Then remove the switch, lifting it by the frame. Make sure that the lifting sling does not place any strain on the live parts. **DO NOT UNDER ANY CIRCUMSTANCES**, handle the switch by rigging on the insulators or live parts.

\*when supplied

## INSTALLATION

1. If the switch is to be installed in a metal enclosure, drawings showing openings and mounting holes must be provided. Four (4)  $3/8$  inch diameter holes in the base of the switch permit the vertical positioning adjustment. Provision should be made in the mounting surface for lateral adjustment. When the switch is mounted in a metal enclosure, the mounting surface must be flat and true to avoid twisting the switch frame when it is bolted down. Such distortion of the frame can affect the adjustment of switch live parts, necessitating realignment of switch blades.

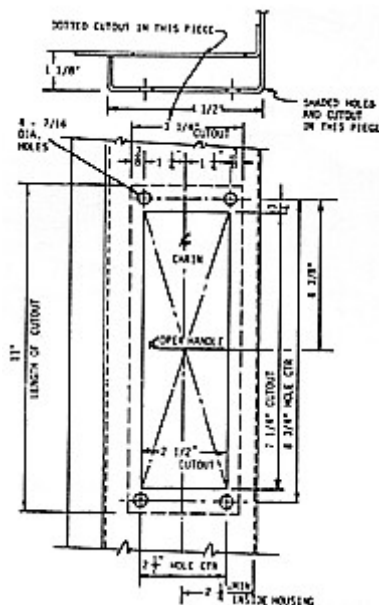

### **Cutout and Mounting for Operating Handle**

2. Use  $1/4$ -inch bolts to bolt the switch to its mounting surface. To avoid distortion of the switch frame, install the upper mounting bolts first (finger tight), then at each lower mounting bolt location. Fill any space between the switch frame and the mounting surface with shims. Then securely tighten all four mounting bolts. When bus or cable is connected to the switch it is important that no strain is put upon the switch terminal pads. Such strain can distort the switch's live parts and may result in improper switch operation. Make sure - before making any connection, the bus or cable connector is aligned with and flat against the terminal pad. Do not use the connecting bolts as a means of pulling the bus or cable into position.

3. Position the outboard sprocket of switch as required and align it with the operating-handle sprocket position. See Figure 2 on page 4.

4. For the operating-handle sprocket location, select the shorter length of chain furnished. (a 24-inch length of #40  $1/211$  pitch chain is suggested for switches with main contacts at top. **Remove chain links accordingly.**) Pass the chain around the handle sprocket such that, with the handle in mid-position, the free ends of the chain are about the same length when extended. See Figure 3 located on page 4. Place the handle in the latched-closed position. Handle "Up"

- switch must be closed.

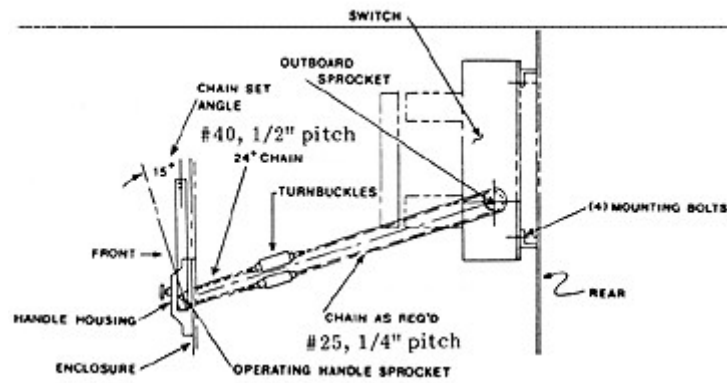

Figure 2

5. Couple turnbuckles to each end of the above chain. Extend each turnbuckle to its maximum length. Then using the longer length of chain provided (#25 1/4" pitch), connect it to extend from one turnbuckle, around the switch drive sprocket and back to the other turnbuckle. Remove chain links to make chain about two links longer than required to go from one turnbuckle to the other.

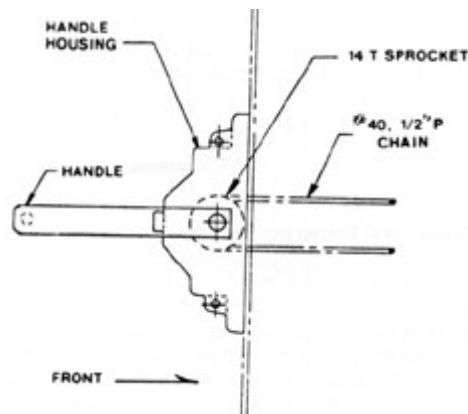

Figure 3

6. Move operating handle approximately 150 from its vertical "up" position and hold it in this position. Connect chains and turnbuckles until chain tension is even and fairly tight (1/2 inch deflection). Move handle back "up" into its locked-closed position.



## SWITCH ALIGNMENT

### Step I

Remove cotter pins and clevis pins that connect pushrods to operating arms of each pole of switch. See Figure 4.

### Step 2

By pulling outward on switch blade, disengage switch blade from jaw casting. Continue to pull outward on switch until arcing blade disengages with arc chute. **Caution should be exercised in this step, due to the fact that the arcing blade is under spring pressure.** See Figure 5.

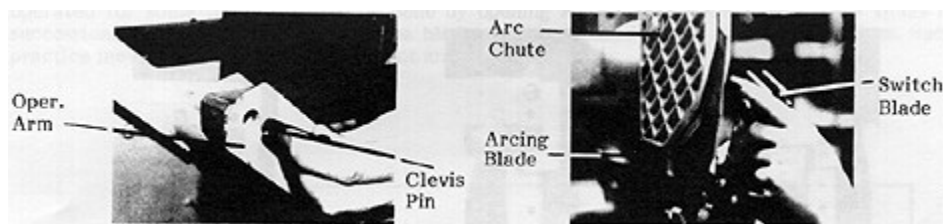

Figure 4

Figure 5

### Step 3

Slowly move blade in and out to check proper alignment of arcing blade to arc chute. See Figure 6.

### Step 4

Alignment of arcing blade and switch blade to arc chute and jaw casting respectively is obtained by loosening jaw casting mounting bolts and lightly tapping arc chute mounting bracket. Re-tighten bolts. See Figure 7.

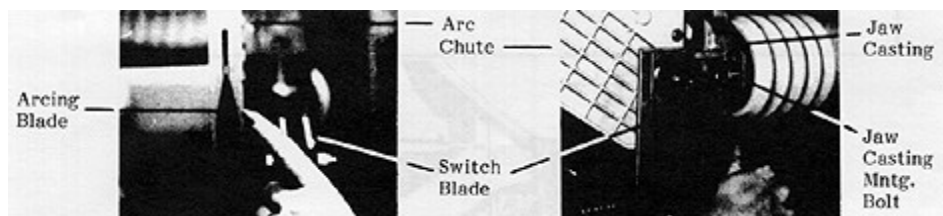

Figure 6

Figure 7

After Steps 2 thru 4 have been completed for each pole, you are now ready to proceed to check the clearance of main blade to jaw casting.

### Adjustments for Clearance of Main Blade to Jaw Casting

Push inward on main blade until contact is made between main blade through bolt and jaw casting.

After you have properly executed the above procedure, you should have a proper main blade through bolt to jaw casting clearance. This clearance is adequate to insure that the main blade through bolt does not bottom on jaw casting, creating unnecessary stress on insulators, castings and connection points. This clearance is also necessary for proper positioning of arcing blade in arc chute as illustrated in Figure 8.

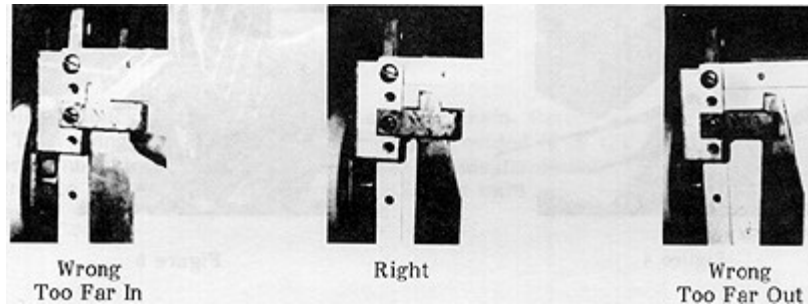

**Figure 8**

By applying pressure as illustrated in Figure 9, you will be able to check for this clearance. The arcing blade should rest freely in stationary arcing contact with switch "closed" and with slight pressure - it should move to the rear approximately 1/8 inch.

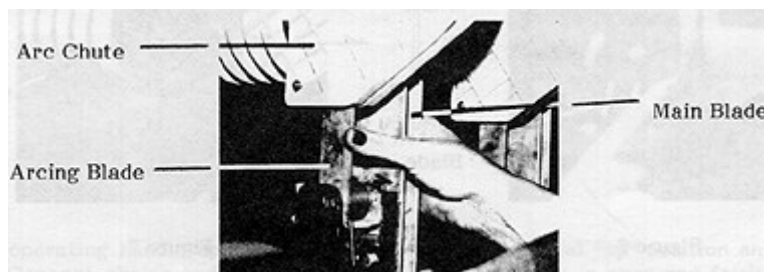
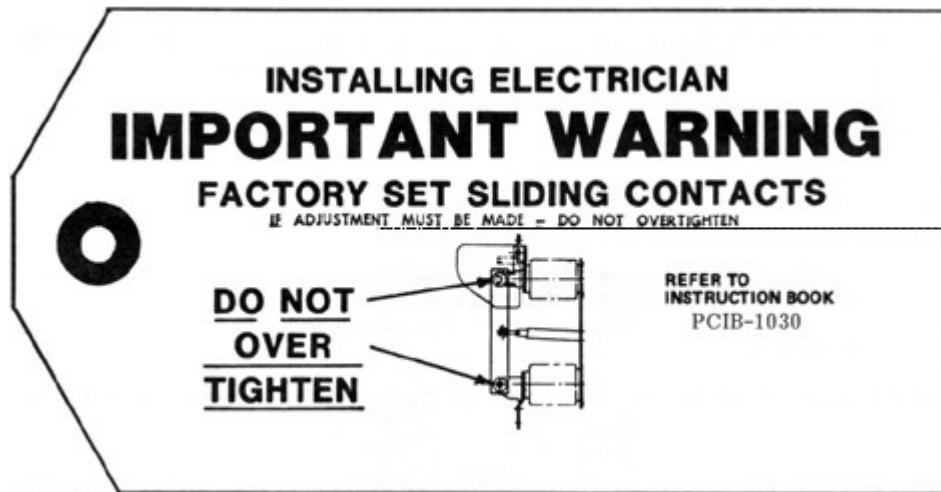

**Figure 9**

## Contacts

Check to determine that the blades make good contact - **IMPORTANT - this is a sliding joint and over tightening can cause the switch not to open and severe damage to the mechanism.** Tighten to approximately 4 to 6 inch pounds. A contact resistance reading should be taken and should be between 35 to 80 micro ohms. If values of resistance are greater than 100 micro ohms, check the blade wipe to insure proper contact. If resistance readings are less, refer to Steps 1 and 2 located on page 5, to insure blades can be "opened" from jaw casting with pulling pressure of approximately 6 to 8 pounds.

Switches are provided with silver to silver contacts. These contacts do not tarnish like copper, but they should be "wiped" clean occasionally, especially if the switch has not been operated for some time. This can be done by opening and closing the switch several times in succession. **Do not attempt to grind the blades with powdered emery or other abrasives.** Such practice inevitably results in poor contact and overheating.



With the completion of all steps of alignment and a final torque check of all mounting hardware, including the jaw casting mounting bolts, the switch is now ready for operation.

## OPERATION

### Description

The powerful opening and closing springs of Powercon's off-center stored energy mechanism provides for quick-make (rated fault closing) and quick-break (rated load interruption). The switch mechanism shaft is driven by a chain and sprocket from the front operating handle. As the handle is rotated, it is directly connected to a sprocket which in turn, chain drives the opening spring to a "charged" position. As the operator continues to rotate the handle, the charged spring is driven off-center by the chain and releases its energy into rotating the operating shaft to open. The switch blades will not move in either a closing or opening direction until the closing spring causes rotation in the operating shaft. It should be noted that once the springs are moved off-center, the operator has no further control of the opening or closing operation. Therefore, the switch has fault-closing and rated load-break features independent of operating personnel performance.

### Sequence of Operation

To Open the Switch:

1. Pull handle latch button to its extreme position. **CAUTION: Failure to clear latch button lever from the housing mechanism can cause extreme damage and jam the operating handle.**
2. Move handle toward the lower position about 150 or until a resistive force is felt in the handle. It is now safe to release the latch button.
3. With a swift positive unhesitating force complete the opening stroke. Once again "off-center" the stored energy mechanism takes over and there is no further control of opening by the operator.
4. Now complete the movement of the operating handle until you feel and/or hear the latch button seat.

To Close the Switch:

Closing procedures are just the reverse of the above except of course, move the handle toward the upper position.

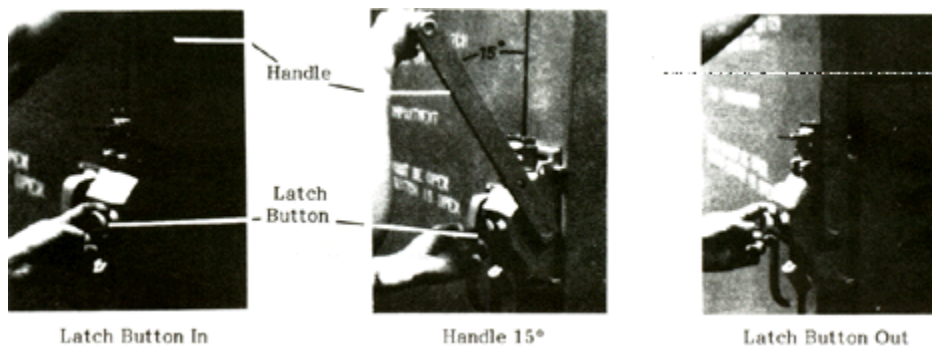

## MAINTENANCE

**BEFORE ANY CHECKING OR MAINTENANCE OF A SWITCH AFTER IT HAS BEEN INSTALLED  
THE FOLLOWING MUST BE OBSERVED:**

### **DANGER HAZARDOUS VOLTAGE**

**DO NOT REMOVE COVERS OR OPEN DOORS OR WORK ON  
EQUIPMENT UNLESS POWER HAS BEEN TURNED OFF AND ALL  
CIRCUITS DE-ENERGIZED AND DISCONNECTED.**

**DISCONNECT, DE-ENERGIZE, LOCK-OUT AND PROPERLY  
GROUND CIRCUIT(S) BEFORE WORKING ON EQUIPMENT**

**USE PROPER SAFETY PRECAUTIONS WHEN WORKING ON THIS  
EQUIPMENT.**

### **SAFETY**

**All safety codes, safety standards and/or regulations as they may be applied  
to this type of equipment must be strictly adhered to. Before any  
adjustments, servicing, parts replacement or any other act is performed  
requiring any physical contact with the electrical components or wiring of  
this equipment, the POWER SUPPLY MUST BE DISCONNECTED.**

**IN ADDITION TO THE PERSONNEL PROTECTION PRECAUTIONS AS OUTLINED  
BELOW, REFER TO ANSI  
STANDARD Z 244.1-1982 ENTITLED:  
PERSONNEL PROTECTION  
LOCKOUT / TAGOUT OF ENERGY SOURCES  
MINIMUM SAFETY REQUIREMENTS**



### **CAUTION**

**BEFORE ANY CHECKING OR MAINTENANCE OF SWITCH-GEAR AFTER IT HAS BEEN INSTALLED-THE  
FOLLOWING MUST BE OBSERVED: ONLY QUALIFIED PERSONS MAY OPER-ATE, INSPECT OR MAINTAIN  
POWER SWITCHGEAR. IN ADDITION TO PERSONNEL YOU MAY HAVE THAT ARE QUALIFIED, OTHERS MAY  
BE AVAILABLE FROM AN EXPERIENCED HIGH VOLTAGE CONTRACTOR OR THE UTILITY SERVICING THE  
INSTALLATION. IT IS THE RESPONSIBILITY OF THE PURCHASER, INSTALLER OR ULTIMATE USER TO INSURE  
THAT THE WARNING VOLTAGE SIGNS ARE NOT REMOVED, MAKE SURE ALL ACCESS DOORS AND  
OPERATING HANDLES ARE SECURELY LOCKED WHEN THE GEAR IS LEFT UNATTENDED BY QUALIFIED  
PEOPLE EVEN MOMENTARILY.**

Disconnect and remove this switch from all sources of electric power so that it is **COMPLETELY DE-ENERGIZED** prior to working on it. This includes **BUT IS NOT LIMITED TO:**

1. The switch supply source of electricity.
2. Back feed of electricity from:
  - A. Motors
  - B. Generators
  - C. Power Transformers
  - D. Potential Transformers
  - E. Control Power Transformers
  - F. Other Sources of Electric Power
  - G. The Outgoing and/or Incoming Distribution System

**CONSIDER THIS EQUIPMENT ALIVE UNTIL ALL SOURCES OF VOLTAGE ARE REMOVED  
AND SAFELY GROUNDED.**

FOLLOW SEQUENCE OF OPERATION ON PRECEDING PAGE 9 BEFORE DOING ANY OF THE FOLLOWING  
PROCEDURES:

### **Periodic Checking**

Load break switches should be examined and checked once a year or more often, when conditions require it (such as numerous operations, polluted atmosphere or overloading of the switch). All switches should occasionally be opened and closed several times in succession - not exceeding their rated duty.

### **Cleaning**

All switches including insulators and operating arms should be thoroughly cleaned Periodically by wiping with a clean cloth to prevent accumulation of dust. After cleaning, a light coat of lubricant (Conducto-Lube contact grease or equivalent) should be applied to the contact surfaces. **Do not use "cup" or other grease which may harden upon exposure to air or freeze at low temperatures.** Consult factory for application temperatures below -25°F..

### **Contacts**

Check to determine that the blades make good contact - **IMPORTANT - this is a sliding joint and overtightening can cause the switch not to open and severe damage to the mechanism.** Tighten to approximately 4 to 6 inch pounds. A contact resistance reading should be taken and should be between 35 to 80 micro ohms. If values of resistance are greater than 100 micro ohms, check the blade wipe to insure proper contact. If resistance readings are less, refer to Steps 1 and 2 located on page 5, to insure blades can be "opened" from jaw casting with pulling pressure of approximately 6 to 8 pounds.

Switches are provided with silver to silver contacts. These contacts do not tarnish like copper, but they should be "wiped" clean occasionally, especially if the switch has not been operated for some time. This can be done by opening and closing the switch several times in succession. **Do not attempt to grind the blades with powdered emery or other abrasives.** Such practice inevitably results in poor contact and overheating.

See **INSTALLATION** for aligning and making proper contact.

## Insulators

It is necessary that the insulator surfaces be kept clean. This is absolutely essential, particularly when the switches are located where cement dust, metallic dust, salt spray, acid fumes and other unfavorable environmental conditions exist. Alcohol cleaner or a light detergent is recommended for cleaning the porcelain insulators. **Make absolutely sure that proper ventilation and other precautions are provided when using any chemical cleaner.** Discard and replace any insulator showing signs of treeing or tracking.

## Insulation Check

When making an annual check, all insulation should be carefully examined for tracking. Special attention must be given to areas where the conductor passes through an insulator or lays near a barrier. Examine the surface for cracks or streaked discoloration. When tracking is found, the insulation involved must be replaced.

## Bus & Conductor (Switch Blade) Check

Inspect the buses and connections carefully every year for evidence of overheating. It is desirable to measure the resistance to ground with a meter (or use a megger of proper voltage) and between phases of the insulation of buses and connections. A record should be kept of this reading. Weakening of the insulation from one maintenance period to the next can be recognized from the recorded readings. At the recording time, the record should also include the temperature, humidity and the date.

## Chain Drive

The chain drive assembly connects the stored energy mechanism to the operating handle on the front of the housing. It consists of a length of roller type chain fastened in a loop by two turnbuckles with locking nuts. All chain assemblies are factory adjusted and adjustment should not be required when switch is supplied in a cubicle. (See **INSTALLATION** for customer supplied cubicles). If for some reason the chain has loosened, increase tension with turnbuckles so that 1/2 inch slack is obtained.

## Operating Shaft

The operating shaft connects the stored energy mechanism to the switch operating arms. The shaft is integral with the switch assembly and is bearing mounted. Light lubricant applied to bearing surfaces will insure trouble free operation. No adjustments are necessary.

## Pushrods

Each main blade of the switch is connected to the throw arms or the main operating shaft by an insulating pushrod. These rods should be examined during each normal maintenance procedure, for signs of damage to either end of the pushrod. If a damaged pushrod is encountered, replacement parts may be obtained by referring to **ORDERING OF SPARE PARTS** section of this manual.

## Stored Energy Mechanism

The stored energy mechanism consists of a housing with a one piece crank sprocket assembly supported by bearings and a spring assembly.

The sprocket assembly is chain driven by means of a handle on the front of the housing. As the handle is moved upward, the spring assembly is charged. As the crank sprocket assembly passes over dead center, the spring takes over and instantaneously moves the switch to closed position.

The unit is factory adjusted and should need no adjustment in the field. The only moving parts which should be checked after approximately 100 operations, are the front and rear latches which are spring operated and the two shaft bearings. Check to make sure the latches rotate freely up and down by using finger pressure on the rollers. See Figure 10.

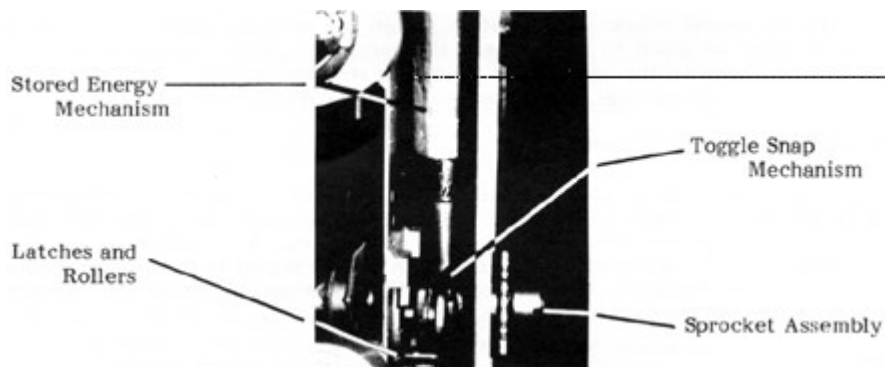

**Figure 10**

### **Lubrication**

The load break interrupter switch requires infrequent lubrication. Bearing points and sliding surfaces should be lubricated at the regular inspection periods with a thin film of lubricant (Lubriplate #107 or "Low Temp"). Before lubricating, remove any hardened grease and dirt from latch and bearing surfaces with kerosene.

The contact surface of the moveable blades and the stationary contact surface should be cleaned and greased with a light coat of conducting grease (Conducto-Lube contact grease

or equivalent).

### **High Potential Tests**

High potential tests to check the integrity of the insulation are not necessary if the insulation maintenance in this book are carefully followed. Should the purchaser desire to make high potential tests, the test voltage should not exceed 14KV A.C. for 4.16KV and 19.5KV A.C. for 7.2KV equipments. These voltages are 75% of factory test voltages and are in accordance with ANSI standards.



## TROUBLESHOOTING

### HIGH VOLTAGE FUSES AND DISCONNECT SWITCHES

#### TROUBLE: OVERHEATING

Cause:	Remedy:
Overload	If the switch is overheating because of excess current, one of two remedies can be adopted: 1. Replace switch with one of adequate rating 2. Rearrange circuits to remove the excess load
Poor Contact	Adjust contacts
Connections to Switch Not of Adequate Current-Carrying Capacity	Increase the capacity of the connections by adding conductors or by replacing with heavier conductors.
Contacts Burned or Pitted	Contacts should be dressed and fitted properly
Bolts and nuts of Connections Not Tight	Tighten all bolts and nuts. Too much pressure must not be used in tightening nuts on bolts. The use of too large a wrench may cause such excessive pressure that the expansion of the bolts exceeds their elastic limit, leading to more loosening of the connections
Located in Too Hot an Ambient (such as too close to a boiler or furnace)	Relocate in a cooler place or arrange some means of cooling.

#### ORDERING OF SPARE PARTS

The following table is provided as a reference guide to stocking levels of spare parts to minimize downtime when used with a conscientiously applied maintenance program. All items are stock to two weeks delivery.

Cat No.	Name of Part	Qty	5KV		7.2KV	
			200A	400A	200A	400A
C-7704-502	Jaw Casting	None	X	X	X	X
C-7705-502	Hinge Casting	None	X	X	X	X
C-4H24-502	Barrier Clips (Caddy Clips)	None	X	X	X	X
C-12025-502	Arc Chute	3	X	X	X	X
C-12055-502	Main Blade 400A	6 (3 ea)		X		X
C-12065-502	Main Blade 200A	6 (3 ea)	X		X	X
C-40029-502	Quick Break Auxiliary Blade 400A	3		X		
C-45015-502	Quick Break Auxiliary Blade 200A	3	X		X	X
C-90005-502	Insulating Pushrod 5KV	Set of 3	X	X		
C-90015-502	Insulating Pushrod 7.2KV	Set of 3			X	
C-717353-18-502	Porcelain Insulator 7.2KV	4			X	X
C-717027-18-502	Porcelain Insulator 5KV	4	X	X		X

**INSTALLATION AND MAINTENANCE CHECK LIST**

**REMEMBER - KEEP IT CLEAN - KEEP IT DRY AND YOU'LL NEVER HAVE A REASON TO CRY**

CUSTOMER \_\_\_\_\_  
SWITCHGEAR IDENTIFICATION \_\_\_\_\_  
LOCATION OR JOB NAME \_\_\_\_\_  
APPROVED FOR OPERATION BY \_\_\_\_\_

**A. SWITCH BLADES AND ARC BLADES**

- Check arc blade alignments with arc chute and stationary arcing contacts
- Check arc blade clearance with arc contacts
- Inspect switch blade end for silver contacts
- Check switch blade alignment with casting contact
- Check switch blade pressure at jaw casting contact
- Check switch blade torque at hinge casting point
- Insure contact grease is on casting contacts
- Check for proper alignment of switch assembly in cubicle

**B. INSULATORS**

- Inspect pushrods for defect
- Insure cotter pin fasteners are spread apart
- Check switch blade alignment with levers on shaft
- Check length of eye bolt within insulating rod (when applicable)
- Inspect porcelains for defects or dirt
- Insure lightning arrestors are mounted securely (when furnished)
- Check for tightness of nut on porcelain rods (when furnished)

**C. HANDLE MECHANISM**

- Check chain on mechanism for proper tension
- Check handle release knob for freedom of movement
- Check handle positioning top and bottom of casting
- Check handle unit for nameplates (3)
- Inspect adjusting rods for proper length within adjusting bolt \*

**D. CABLE AND BUS**

- Inspect bolts bus connections for tightness
- Check clearance phase to phase and phase to ground of cable and bus
- Bus and cable supports are adequate
- Inspect cables for penciling at ends
- Inspect cable termination in cable lugs for tightness Inspect placement of phase markings
- Check plating on bus bars
- Inspect taped joints for tightness
- Check connections on lugs
- Inspect taped joints for coverage of insulating varnish

**E. KEY INTERLOCKS \***

- Check door block for lubrication
- Check key interlock system for proper sequence and operation
- Insure interlock is free from binding
- Check weathercap fits securely (outdoor only)
- Insure key nameplate matches key number
- Handle stops on casting do not interfere with interlock mechanism

**F. FUSE ACCESSORIES**

- Check contact of fuses mounted in fuse clip
- Inspect unit for spare fuse holder or mounting
- Check alignment of fuses with fuse clips

**G. SWITCH UNIT - GENERAL**

- Inspect phase barriers for secure mounting
- Check unit for manufacturers and nomenclature nameplates
- Inspect paint coverage of unit
- Inspect door handles, locking bars and mechanism
- Inspect for damaged, bent or twisted doors
- Check unit for proper device markings
- Inspect unit for gasketed joints (outdoor only)
- Check unit for water tightness
- Inspect unit for door stop alignment
- Inspect unit doors for proper opening
- Louvers checked for proper back up

**H. MEGGER@\_\_\_\_\_VOLTS\_\_\_\_\_OHMS**

**1. HI POT (75% OF FACTORY)**

**J. REMARKS**

\_\_\_\_\_  
\_\_\_\_\_  
\_\_\_\_\_  
\_\_\_\_\_  
\_\_\_\_\_



P.O. Box 477, 1551 Florida Avenue  
Severn, MD 21144  
Phone: 410-551-6500  
email info@powerconcorp.com