



PCIB-1046A

REV 11/2/90

INSTRUCTION BOOK

HORIZONTAL DRAWOUT METAL-CLAD SWITCHGEAR With Cutler-Hammer Vacuum Circuit Breakers

WARNING

**FOLLOW THE SAFETY INSTRUCTIONS AND WARNINGS
THROUGHOUT THIS BOOK. FAILURE TO DO SO
CAN RESULT IN DAMAGE TO PROPERTY, PERSONAL INJURY, OR DEATH.**

**IN ADDITION TO THE MAINTENANCE AND PRECAUTIONS
AS OUTLINED WITHIN, REFER TO z244.1-1982 ENTITLED:**

**PERSONNEL PROTECTION
LOCKOUT/TAGOUT OF ENERGY SOURCES
MINIMUM SAFETY REQUIREMENTS**

These instructions may not cover all details or variations in equipment, nor provide for every possible contingency encountered. Should further information be desired or should problems arise which are not covered sufficiently, the matter should be referred to the POWERCON CORPORATION

P.O. Box 477, 1551 Florida Avenue, Severn, MD 21144 Phone: 410-551-6500 email info@powerconcorp.com

**WARNING
IMPORTANT**

IT IS IMPERATIVE THAT YOU READ AND COMPLETELY UNDERSTAND THE WARNING LOCATED TO THE RIGHT OF THIS BLOCK, FAILURE TO DO SO CAN RESULT IN DAMAGE TO PROPERTY, PERSONAL INJURY OR DEATH



DO NOT REMOVE COVERS, OPEN DOORS, OR WORK ON EQUIPMENT UNLESS POWER HAS BEEN TURNED OFF AND ALL CIRCUITS DE-ENERGIZED AND DISCONNECTED. DISCONNECT, DE-ENERGIZE, LOCKOUT AND PROPERLY GROUND CIRCUIT(S) BEFORE WORKING ON THIS EQUIPMENT. USE PROPER SAFETY PRECAUTIONS WHEN WORKING ON THIS EQUIPMENT.

ALL SAFETY CODES, SAFETY STANDARDS, AND/OR REGULATIONS AS THEY MAY BE APPLIED TO THIS TYPE OF EQUIPMENT MUST BE STRICTLY ADHERED TO. BEFORE ANY ADJUSTMENTS, SERVICING, PARTS REPLACEMENT OR ANY OTHER ACT IS PERFORMED REQUIRING ANY PHYSICAL CONTACT WITH THE ELECTRICAL COMPONENTS OR WIRING OF THIS EQUIPMENT, THE POWER SUPPLY MUST BE DISCONNECTED.



IN ADDITION TO THE PERSONNEL PRECAUTIONS AS OUTLINED, REFER TO:

- Z244.1-1982 PERSONNEL PROTECTION LOCKOUT/TAGOUT OF ENERGY SOURCES MINIMUM SAFETY REQUIREMENTS
- ANSI/NFPA 70E-1988: ELECTRICAL SAFETY REQUIREMENTS FOR EMPLOYEE WORKPLACES
- ANSI/NFPA 70B-1988: ELECTRICAL EQUIPMENT MAINTENANCE



THE EQUIPMENT COVERED BY THIS INSTRUCTION BOOK MUST BE SELECTED FOR A SPECIFIC APPLICATIONS AND IT MUST BE INSTALLED, OPERATED, AND MAINTAINED BY QUALIFIED PERSONS WHO ARE THOROUGHLY TRAINED AND WHO UNDERSTAND ALL OF THE HAZARDS INVOLVED. As with any electrical apparatus, the thorough knowledge of the engineering safety, inspection, maintenance and repair techniques as well as being familiar with particular features of the apparatus involved is mandatory. THIS BOOK DOES NOT PROVIDE SUFFICIENT INSTRUCTIONS FOR INEXPERIENCED ELECTRICIANS OR UNQUALIFIED PERSONS TO DO ANY WORK REQUIRED INCLUDING THE HANDLING, INSTALLATION, TESTING, OPERATION, INSPECTION, MAINTENANCE, AND REPAIR.



BEFORE CHECKING OR MAINTENANCE OF SWITCHGEAR, AFTER IT HAS BEEN INSTALLED - THE FOLLOWING MUST BE OBSERVED: ONLY QUALIFIED PERSONS MAY OPERATE, INSPECT OR MAINTAIN POWER SWITCHGEAR. IN ADDITION TO THE PERSONNEL YOU MAY HAVE WHO ARE QUALIFIED, OTHERS MAY BE AVAILABLE FROM AN EXPERIENCED HIGH VOLTAGE CONTRACTOR OR THE UTILITY SERVICING THE INSTALLATION. IT IS THE RESPONSIBILITY OF THE PURCHASER, INSTALLER, OR ULTIMATE USER TO INSURE THAT THE WARNING SIGNS ARE NOT REMOVED AND TO MAKE SURE THAT ALL ACCESS DOORS, AND OPERATING HANDLES ARE SECURELY LOCKED WHEN THE GEAR IS LEFT UNATTENDED BY QUALIFIED PERSONS, EVEN MOMENTARILY.



SAFETY GROUNDING TO BE DONE ON DE-ENERGIZED EQUIPMENT ONLY.

Before energizing the equipment and prior to any testing it is recommended that all circuits be safely grounded. Prior to any grounding whether it be for any testing, inspection, or maintenance procedures, assure that all safety precautions are taken. It is further recommended that an appropriate properly operating glow tube instrument that lights up and warns the worker when held in any alternating current field, indicating the presence of voltage, be used prior to grounding.

PERSONNEL DOING SUCH WORK SHOULD WEAR LINEMAN'S PROTECTIVE EQUIPMENT IN ACCORDANCE WITH SUCH EQUIPMENT MANUFACTURER'S RECOMMENDATIONS INCLUDING BUT NOT LIMITED TO PROTECTIVE GLOVES, INSULATED SLEEVES, LINEMAN'S BLANKETS, INSULATED HELMETS, FACE AND EYE PROTECTION that will assist in preventing injury if for any reason the equipment is grounded to an energized circuit. Every precaution should be taken to prevent electrical grounding on an energized circuit. Suitable grounding clamp leads should be used and safety grounding techniques employed. ALL SUCH GROUNDS MUST BE REMOVED AFTER TESTING, INSPECTION, OR MAINTENANCE PRIOR TO ENERGIZING THE EQUIPMENT.

In as much as Powercon has no control over the use to which others may put this material, statements concerning uses of the materials described herein are not to be construed as suitable for these used unless proper technology in the usage, applications, and maintenance are strictly observed. For further information call or write the Powercon Corporation.



LIMITED WARRANTY

Powercon warrants that the equipment we deliver will be of the kind and quality described in the order or contract and will be free of defects in workmanship and material. Should any failure to conform to this warranty appear within one year after date of shipment, Powercon shall upon prompt notification thereof and substantiation that the equipment has been stored, installed, operated and maintained in accordance with Powercon recommendations and standard industry practice, correct such nonconformities, at its option, either by repairing any defective part or parts or by supplying a repaired or replacement part or parts F.O.B. factory. However, if Powercon has installed the equipment or furnished field engineering services with respect to its installation, and provided such installation has not been delayed by the Purchaser, said one year shall run from the completion of the installation. The total warranty period shall not exceed 18 months from the date of shipment in any case.

In no event shall Powercon be responsible for providing working access to the defect, including the removal, disassembly, replacement or reinstallation of any equipment material or structures to the extent necessary to permit Powercon to perform its warranty obligations, or

transportation costs to and from the Powercon factory or repair facility. The conditions of any tests shall be mutually agreed upon and Powercon shall be notified of, and may be present at, all tests that may be made.

THE WARRANTIES SET FORTH IN THIS PROVISION ARE EXCLUSIVE AND IN LIEU OF ALL OTHER WARRANTIES WHETHER STATUTORY, EXPRESS OR IMPLIED (INCLUDING ALL WARRANTIES OF MERCHANTABILITY AND FITNESS FOR PARTICULAR PURPOSE AND ALL WARRANTIES ARISING FROM COURSE OF DEALING OR USAGE OF TRADE), EXCEPT OF TITLE AND AGAINST PATENT INFRINGEMENT. The remedies provided above are the purchaser's sole remedies for any failure of Powercon to comply with its obligations. Correction of any nonconformity in the manner and for the period of time provided above shall constitute complete fulfillment of all the liabilities of Powercon whether the claims of the Purchaser are based in contract, in tort (including negligence) or otherwise with respect to or arising out of the equipment furnished hereunder

WARRANTY IMPLEMENTATIONS AND CONDITIONS

On those occasions where service help is required, the Powercon Corporation should be notified at once through its Service Department. No charges or expenses should be incurred except as authorized by the Corporation in writing. Making unauthorized corrections or doing unauthorized work voids this Warranty and renders reimbursement impossible.

At times, the Powercon Corporation may request labor and/or material services from you. At our option we will provide competent supervision who will authorize such

services by signing the Time Sheets of the people involved. No reimbursement can be made without signed Time Sheets.

The services rendered must be of the type and quality satisfactory to the Powercon Corporation, and we reserve the right to reject any and all such services.

The above in no way prejudices the right of the Powercon Corporation to correct, as stipulated in the Warranty, any problems that may occur in equipment manufactured by the Powercon Corporation.

FOREWORD

This Instruction Book is furnished in "As is" condition. No warranties expressed or implied, including warranties of fitness for a particular purpose, or merchantability, or warranties arising from course of dealing or usage of trade are made regarding the information, recommendations, descriptions, and safety notations contained herein. In no way will Powercon be responsible to the user in contract, in tort (including negligence), strict liability or otherwise for any direct special, indirect, incidental, or consequential damage or loss whatsoever, including but not limited to damage or loss of use of equipment, plant, or power system, cost of capital, loss of profits or revenues, cost of replacement power, additional expenses in the use of existing

power facilities, or claims against the user by its customer resulting from the use of information, recommendations, descriptions, and safety notations contained herein.

The information, recommendations, descriptions, and safety notations in this document are based on Powercon's experience and judgment in respect to all of the subject matter contained herein. This information must not be considered to be all inclusive or covering all contingencies.

TABLE OF CONTENTS

INTRODUCTION	Page 1
SAFETY	
General.....	Page 1
Specific	Page 1
RECEIVING, HANDLING, AND STORAGE	
Receiving.....	Page 1
Handling	Page 1
Storage	Page 2
DESCRIPTION	
Housing.....	Page 2
Secondary Enclosure	Page 2
Primary Enclosure.....	Page 2
Breaker Removal Element	Page 2
Secondary Disconnecting Device.....	Page 2
Bus Compartment	Page 2
Current Transformers.....	Page 3
Shutters.....	Page 3
Control Power Transformers	Page 3
Primary Termination Space.....	Page 3
Voltage Transformers.....	Page 3
Secondary Coupler.....	Page 3
Rackout Mechanism Operating Handle	Page 3
Stationary Auxiliary Switch.....	Page 3
Position Switch.....	Page 3
Outdoor Equipment.....	Page 3
INSTALLATION	
Location	Page 4
Anchoring Indoor Equipment	Page 4
Anchoring Outdoor Equipment.....	Page 4
Control Cables	Page 4
Ground Bus.....	Page 4
Lightning Protection	Page 4
Connections	Page 4
Main Bus Assembly.....	Page 5
Insulated Bus Systems.....	page 5
Taped Joints.....	Page 5
Cleaning Bus Insulation	Page 6
Primary Cables.....	Page 6
Removable Breaker Element.....	Page 6
Breaker Racking Mechanism.....	Page 6
Roof Entrance Bushing	Page 6
Primary Disconnects	page 6
Dummy Removable Elements.....	Page 6
Ground and Test Device.....	Page 6
OPERATION	
Breaker Installation and Removal	Page 7
Lifting of Breaker.....	Page 7
Levering Device Assembly	Page 7
Spring Discharge Interlock.....	Page 9
Truck-Operated Switch.....	Page 9
Mechanism-Operated Switch.....	Page 9
Secondary Disconnecting Cables.....	Page 9
Breaker Position Interlock.....	Page 9
Interference Interlock	Page 9
Test Cabinet.....	Page 9
Transfer Trucks.....	Page 9
TESTING AND INSPECTION	
Testing and Inspection	Page 9
Breaker Operation Test	Page 10
Key Interlocks.....	Page 10
Space Heaters.....	Page 10
Fuse Carriage.....	Page 10
INSPECTION AND MAINTENANCE	
Recommended Annual Maintenance	Page 10
Instrument Compartments.....	Page 11
RENEWAL PARTS	Page 11

INTRODUCTION

This book contains instructions for installing, operating, and maintaining Horizontal Drawout Metalclad Switchgear equipment. It should be read carefully before installation and initial operation of this equipment.

Separate publications will be supplied for breakers, relays and other devices not described in this publication.

In addition to instruction books, the following drawings will be supplied:

1. Front View and Floor Plan drawings which show the general arrangement, recommended aisle space, etc.
2. Summary of Switchgear Equipment which is a partial parts list, giving catalog number of all breakers, devices, etc.
3. (a) Control Wiring Diagram
(b) Elementary of Schematic Wiring Diagrams

All of these documents are needed for installation, operation and maintenance of equipment.

SAFETY

(Refer to Instruction Book PCIB-1043 which forms part of these instructions)

Each user is responsible for communicating all safety instructions and practices to personnel associated with this equipment.

The following practices should be included in a user's safety program. These do not supplant the user's responsibility for devising a complete safety program. They are rather suggestions concerning some aspects of personnel safety related to circuit breakers and metalclad switchgear equipment. Powercon assumes no responsibility for user practices which deviate from these recommendations.

Although the interlock linkage has been designed to be rugged, inadvertent bending of the spring discharge and/or negative interlock actuating linkages during breaker storage, lift truck or stack insertion operations could negate their proper functioning and therefore create a safety risk. This type of handling damage must be avoided by any user.

All servicing of switchgear must be performed only by trained personnel with **BOTH THE PRIMARY AND CONTROL POWER CIRCUITS DE-ENERGIZED.**

General

1. The term "metalclad switchgear" includes circuit breakers, associated interrupting, switching control, metering and protective devices, together with their supporting metal structures enclosures, electrical connections and accessories.
2. All personnel associated with installation, operation and maintenance of metalclad switchgear should be thoroughly instructed and supervised regarding power equipment in general as well as the particular model of equipment with which they are working. Instruction books should be closely studied and followed.
3. Maintenance programs must be well planned and carried out in a manner consistent with both customer experience and manufacturer's recommendations. Good maintenance is essential to electrical equipment reliability and safety.

Specific

1. DO NOT work on any energized breaker. If work has to be performed on the breaker, rack it out and de-energize the spring charged mechanism. Once the breaker has been de-energized, all control power must be disconnected before servicing

2. All spring-charged mechanisms related to a breaker must be serviced only by skilled and knowledgeable personnel capable of releasing each spring load in a controlled manner. Particular care must be "exercised to keep personnel clear of mechanisms which are to be operated or released. Information on construction of such mechanisms is provided in the instruction book for the particular breaker.
3. DO NOT approach or service any equipment which is normally energized by any switchgear unless the breaker is in the disconnect/test position. In this disconnect/test position the load bus must be adequately grounded and the breaker secured.
4. If there is any evidence of or suspected deterioration of breaker dielectric capability, adjacent areas should be promptly cleared of personnel. The breaker should then be dc-energized by "backups" and isolated.

RECEIVING, HANDLING, AND STORAGE

Receiving

Every case or package leaving the factory is plainly marked with case number, requisition number and customers order number. If it is necessary to divide the equipment for shipment, the unit number of the portion of the equipment enclosed in each shipping package is marked on that package..

The contents of each package of the shipment are listed in the packing details attached to the package. To avoid the loss of small parts when unpacking, the contents of each case should be checked against the packing details before discarding the packing material. Notify the nearest POWERCON CORPORATION representative at once if any shortage of material is discovered.

All equipment leaving the factory is carefully inspected and packed by personnel experienced in the proper handling and packing of electrical equipment. Upon receipt of the equipment, an inspection should be made immediately to detect any damage sustained while enroute. If damage is evident or an indication of rough handling is visible, a claim should be filed with the transportation company and the POWERCON CORPORATION should be notified promptly. Information on damaged part, part number, case number and requisition number should accompany the claim.

Handling

The switchgear units are most conveniently handled by a crane. A cable spreader must be used when lifting with a crane in order to obtain a vertical pull.

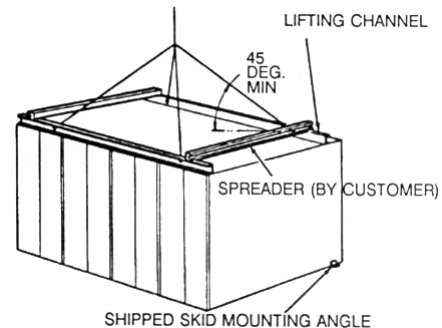

If crane facilities are not available, the equipment may be moved into position by means of construction rollers placed under the shipping skid. Jacks may also be used to handle the equipment when a crane is not available.

All outer crating provided should be removed after the equipment has been moved to the desired location. Methods of handling outdoor equipment are shown below. Outdoor switchgear is not shipped on a skid.

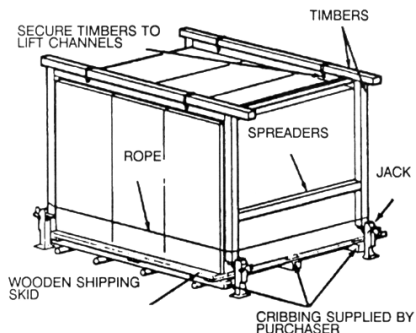

Storage

If it is necessary to store the equipment for any length of time, the following precautions should be taken to prevent breakage, corrosion, damage or deterioration:

1. Uncrate the equipment. Check it thoroughly for damage.
2. Store in a clean dry place with moderated temperature and cover it with a suitable cover to prevent dust, dirt, water, or other foreign substances from entering the switchgear.
3. Cover important parts such as jack screws, gears, and the chain of the racking mechanism, linkage and moving part with a heavy oil or grease.
4. Batteries should be uncrated and put on trickle charge immediately on receipts
5. If dampness or condensation is encountered in the storage location, heaters should be placed inside the units to prevent moisture damage. Approximately 500 watts of heater per unit will be required. Remove all cartons and other miscellaneous material packed inside units before energizing any heaters. If the equipment has been subjected to moisture, it should be tested with a 1000V or 2500V megger. A reading of at least 200 megohms should be obtained. On outdoor switchgear, dampness or condensation can be prevented by making a temporary power supply connection to the heaters already installed in the equipment.

WARNING

BE SURE THAT FUSES TO CPT SECONDARY HAVE BEEN REMOVED BEFORE ENERGIZING THE TEMPORARY CONNECTION TO THE HEATERS. THIS IS TO PREVENT A BACK FEED OF HIGH VOLTAGE AT CPT PRIMARY.

DESCRIPTION

The switchgear consists of one or more units which are mounted side by side and connected mechanically and electrically to form a complete switch equipment.

Each metalclad unit consists of a stationary housing and a removable breaker element. The stationary housing is compartmented and

contains the instrument panel, bus compartments, breaker compartment and cable or termination compartment. Each of these compartments is enclosed in grounded sheet metal.

The circuit breakers are easily removable to provide maximum accessibility for maintenance with minimum safety interruption.

The ratings of the equipment and devices are based on usual service conditions as covered in the USASI Standards.

For outdoor use the same basic equipment is enclosed in a weatherproof steel housing.

The principle parts and features of the metalclad equipment are described in greater detail in the following paragraphs.

Housing

The metalclad housings are made of steel members welded or bolted together to form rigid, self-supporting units with metal barriers between the different enclosures.

Each unit is basically divided into a secondary and primary enclosure as described below.

Secondary Enclosure

The secondary enclosure is located in front of the breaker compartment on the breaker withdrawal side of the unit. It consists of a compartment with hinged and latched doors on which can be mounted instruments and control and protective devices. Terminal blocks, fuse blocks, and some control devices are mounted inside the enclosure and troughs are provided at the top and bottom to carry wiring between units.

Primary Enclosure

The primary enclosure contains the high voltage equipment and connections. It consists of the breaker compartment, the bus compartments and the cable termination compartment. Each of these compartments is separated from the others by metal barriers for maximum reliability and safety.

Breaker Removable Element

The removable element consists of a circuit breaker with a tripfree operating mechanism, an interlocking mechanism, the removable portion of the primary and secondary disconnecting devices, the operating mechanism control device and the necessary control wiring, the racking mechanism, stop pins, the position indicator, and the necessary pins and rollers for operating the housing shutters, auxiliary switch and position switch. The breaker is mounted on unidirectional wheels for each insertion and removal. The front panel on the breaker becomes the front cover of the housing when the breaker is in the connected position.

Secondary Disconnecting Device

Stationary secondary connection devices are mounted in the breaker compartment. Cooperating spring loaded sliding finger contacts are mounted on the breaker. Both stationary and movable contacts are silverplated.

Bus Compartment

The main buses are enclosed in a metal compartment with removable front covers to provide accessibility.

The bus is supported by a flame retardant, track resistant, glass laminate insulating material which is practically impervious to moisture and an excellent dielectric. No additional coating should be applied. 15 K-V bus supports are porcelain inserts.

The bus insulation is an extruded thermoplastic insulation sleeve, suitable for 105 degree C operating temperature. The bus bars are inserted into the sleeves leaving only the bolted joints exposed. are again "mudded" and taped or "booted" as described later.

All bolted joints in the buses are made with silverplated connections.

Current Transformers

A maximum of six current transformers can be mounted over the primary disconnecting devices in the breaker compartment and in this position they are accessible from the front of the unit. Additional current transformers, when required, can be mounted in the cable compartment in Year. The primary power source must be de-energized before any work is done on the current transformers.

Shutters

Grounded metal shutters, which cover the stationary part of the primary disconnecting devices, are provided in all breaker compartments. These shutters are automatically actuated to open and close in response to the movement of the breaker into or out of the compartment.

The shutters consist of two pivotally mounted grounded steel plates which rotate to cover the openings in the front of the primary disconnect tubes when the breaker is moved from the connected to the test position. The shutters are fully closed in the test position and remain closed with the breaker in the disconnect position and removed from the housing. These shutters are intended to prevent access to primary conductors in energized breaker compartments when the breakers are removed. No attempt should be made to defeat their purpose-

Control Power Transformers

Control power transformers are located in the rear of the auxiliary compartment or remote from the switchgear.

Their associated primary fuses are mounted on a carriage in the front of the auxiliary compartment. Interlocked doors on the front of the carriage provide access to the fuses after the carriage has been withdrawn to a disconnected position.

Spring loaded disconnect devices on the carriage connect the primary windings of the transformer to either the bus or to other primary circuits as required.

A non-automatic molded case circuit breaker and associated fuses are mounted behind the left hand upper door of the auxiliary compartment. A key interlock is provided to prevent fuses from being withdrawn under load.

Primary Termination Space

The primary termination space of each breaker unit is isolated from the other equipment by metal barriers. Space is provided in this compartment for connecting the purchaser's primary cable by means of potheads or clamp-type terminals. Two-hole NEMA drilling for two cables per phase is provided at all cable connection points.

In double breaker vertical sections, a steel duct serves as a pull-box and barriers to separate the two outgoing cable circuits.

The primary termination space of a unit is accessible by removal of the bolted rear cover.

Voltage Transformers

Voltage transformers are located in an auxiliary unit. Up to three transformers can be mounted on a movable carriage equipped with primary and secondary disconnecting devices. When the voltage transformers are disconnected, they are at a safe striking distance from all live parts of the switchgear. In addition, a grounding device is provided which contacts the fuses when the voltage transformers are disconnected, effectively discharging the transformer. In this position the transformer fuses may be safely removed and replaced. A barrier mounted at the rear of the carriage moves with the carriage to a position in front of the stationary part of the primary disconnect device, providing a safe striking distance from all live parts.

Secondary Coupler

An extension cable with secondary couplers, one of which can be attached to the stationary blocks in the house and the other to the

breaker secondary disconnects, is furnished so that the breaker can be operated outside the house for testing purposes.

Rackout Mechanism Operating Handle

This handle is used to manually operate the breaker racking mechanism. It is a crank type handle with a cross pin in the end which engages in slots in the coupling on the end of the racking mechanism jackscrew.

Stationary Auxiliary Switch (Optional)

A stationary auxiliary switch can be furnished in the equipment when requested. This switch is operated by a plunger off of the breaker mechanism and can be used for remote indication of the position of the breaker contacts or for control circuits which are dependent upon the position of the breaker contacts. The switch is spring returned to its original position when the breaker is opened.

Position Switch(Optional)

A cam operated position switch can be furnished as an accessory when requested. The purpose of this switch is to indicate the position of the breaker in the house by the relative position of its contacts.

Outdoor Equipment

Outdoor metalclad switchgear is constructed as basic indoor equipment completely enclosed in a weatherproof steel housing. It is available in three style.

1. Standard Outdoor
2. Protected Aisle Outdoor
3. Common Aisle Outdoor

1. Standard Outdoor

The standard outdoor enclosure provides a minimum depth equipment. There is a weatherproof hinged door on the front (breaker withdrawal) side of each unit. Opening this door gives access to the breaker and the instrument control panel. The breaker can be moved to the disconnect position for storage within the outdoor enclosure.

The breakers must be removed from the outdoor housings for inspection and maintenance. A transfer truck is provided for breaker removal.

2. Protected Aisle Outdoor

The protected aisle outdoor equipment provides a walk-in aisle enclosure in front of the basic indoor units. The width of the aisle permits transfer of the breakers from one unit to another and provides space for inspection and maintenance of the breakers within the enclosure. An access door is located at each end of the aisle. The basic indoor portion with its weatherproof enclosure is factory assembled in shipping split lengths. The aisle portion, which consists of prefabricated end walls, front wall, roof and floor base, is shipped assembled in shipping split lengths.

3. Common Aisle Outdoor

Common aisle equipment is similar to protected aisle except that there are two lineups of basic indoor equipment with outdoor enclosures arranged face-to-face and jointed by the aisle enclosure. The aisle enclosure permits transfer of breakers from one lineup to the other or between units in the same lineup. An access door is located at each end of the aisle. The basic indoor portions with their weatherproof enclosures are factory assembled in shipping split lengths. The prefabricated aisle is shipped knocked down and is field assembled after the basic equipments have been set in place.

INSTALLATION

Before any installation work is done, consult and study all drawings furnished by the Powercon Corporation for the particular requisition. These drawings include arrangement and floor plan drawings, elementary, connection and interconnection diagrams and a device summary.

Occasionally additional shipping members are installed in the primary area to protect against shipping damage.

WARNING

SHIPPING BRACES MUST BE REMOVED PRIOR TO ENERGIZING. SHIPPING BRACES ARE MARKED WITH YELLOW LABELS. SHIPPING BRACES MAY BE APPLIED TO DEVICES AS WELL AS TO CURRENT-CARRYING CONDUCTORS.

After shipping braces have been removed, all joints must be properly tightened and insulated before energizing the bus.

Mats, screens, railings, etc. which are external to the switchgear, but which may be required to meet any local codes, must be furnished by the purchaser.

Location

The recommended aisle space required at the front and at the rear of the equipment is shown on the floor plan drawing furnished for the particular requisition. The space at the front must be sufficient to permit the insertion and withdrawal of the circuit breakers, and their transfer to other units. No part of a foundation "PAD" or "SIL" may extend more than 3 inches beyond the front of the equipment.

The space at the rear must be sufficient for installation of cables, and for inspection and maintenance.

Anchoring Indoor Equipment

Floor Preparation

The station floor must be strong enough to prevent sagging due to weight of the switchgear structure and to withstand the impact stress caused by the opening of the circuit breakers under short circuit conditions. The impact loading is approximately 1-1/2 times the static load.

Suitable means must be provided by the purchaser for anchoring the equipment to the floor. It is essential that the floor be level to avoid distortion of the switchgear structure and that the equipment be completely aligned prior to final anchoring. The recommended floor construction is shown. The floor channels must be level and straight with respect to each other. Steel shims should be used for final leveling of the switchgear, if necessary. Care should be taken to provide a smooth, hard, and level floor under and in front of the units to facilitate installation and removal of the breaker. If the floor is not level and flush with the floor channels, it will be difficult to handle the breaker because it will not be level with respect to the stationary element.

The switchgear structure can be secured by bolting it to the floor channels using at least 5/8 inch bolts at the locations shown. Plug welding can also be used at the same locations if desired.

Provision should be made in the floor for conduits for primary and secondary cables located as shown on the floor plan drawing furnished for the particular requisition. If desired, the conduits may be installed before the switchgear. Consideration should be given to conduits which might be required for future connections. Conduits must extend no more than one inch above the finished floor prior to the installation of the switchgear. If shipped in more than one section, shipping sections must be assembled in the proper sequence due to the location of conduits. The left-hand section of a switchgear line-up must be positioned in its final location first. Then the section located immediately to the right must be positioned as close as the lifting members permit with the front in alignment with the first section. Remove the lifting members and then push or jack the unit to the left until it is flush with the first section. Be sure to distribute the forces over the side frame using appropriate timbers so as not to deform or damage the surface of the structure.

Anchoring Outdoor Equipment

Switchgear support should be concrete or reinforced concrete with depth, fill, drainage, etc. according to recommended foundation design

for the loading, type of construction, and local conditions involved. The base furnished with the switchgear should be supported on a level surface over the full area of the switchgear. Steel supporting members should be furnished if required for leveling the foundation and supporting the switchgear.

Primary and secondary conduits should be installed in accordance with the requisition drawings before the equipment is put into place. Conduits must extend no more than one inch above the finished floor prior to the installation of the switchgear.

When outdoor pieces of equipment are shipped in more than one section, the roof joint between the sections must be assembled. Shipping sections must be assembled as described for indoor equipment.

Control Cables

When control cables enter the unit from below, the conduit should not extend more than one inch above the floor. The control cables may be pulled through the conduits before or after the switchgear is installed, whichever is more convenient.

Control cables should be guided toward the side sheet and run behind the track assembly. This will prevent the circuit breaker or rollout carriage from interfering.

Connect the cables to the terminal blocks in accordance with the wiring diagrams furnished for the requisition.

The cables from the control power source to the switchgear should be large enough to avoid excessive voltage drop when the circuit breakers are operated. See testing instructions.

Where units have been split for shipment, any control or other secondary leads which must connect across the split will be arranged with terminal blocks at the top or on the side sheet so that the wires can be reconnected. The wires will be cut to length and formed before being folded back so that a minimum of time will be required for reconnecting them.

Ground Bus

Where the equipment is shipped in more than one section, the ground bus must be connected by using the splice plates furnished with the equipment. Assemble the ground bus joints as outlined under "Connections".

The ground bus is bolted to the rear of the frame near the bottom. It is arranged so that connections to the station ground can be made in any vertical section. Ground bus risers are provided in each cable compartment to provide a convenient place to ground cable armor, cable sheath, shields or ground wires. The switchgear ground bus must be connected to the station ground bus by a conductor having current carrying capacity equal to that of the switchgear ground bus. It is very important that the equipment be properly grounded to protect the operator from injury when short circuits or other abnormal occurrences take place, and to insure that all parts of the equipment, other than live parts, are at ground potential.

Lightning Protection

It will be the responsibility of the purchaser to specify suitable surge arrestors to protect the switchgear from damage due to lightning.

Connections

1. Bolt the steel sections together using provided bolts, lockwashers, and nuts.
2. Connect the main buses together using the splice plates and hardware furnished with the equipment. The silvered surfaces on both the main bus and the splice plates should be wiped clean. Sandpaper or abrasives should not be used on the silvered surfaces. After cleaning apply contact grease to the surfaces in sufficient quantity so that the contact area will be thoroughly sealed with excess grease squeezed out of the joint when tightened. The voltages should be tightened to the torqued values shown on next page. After the bolts have been securely tightened, the joints are taped or booted. See "Insulation Instructions".

Bolt Size	Torque Value in Foot Pounds	
	High Strength Steel	Silicon Bronze
1/4-20	5	5
5/16 - 18	12	10
3/8 - 16	20	15
1/2 - 13	50	40
5/8 - 11	95	55

3. Bus duct and primary cable conduits should line up and connections made to the equipment. Hardware for connecting a bus duct to the switchgear is furnished with the bus duct.
4. The primary cable connections are made on the rear of the circuit breaker unit. The bolted rear covers must be removed for access to the cable area. Before any primary cable connections are made the cables should be identified to indicate their phase relationship with the switchgear connections. This is necessary to insure that motors will rotate in the proper direction and that the phase rotation is the same when interconnecting two sources of power.

There are two common methods of making primary cable connections:

1. Potheads are used when it is desired to seal the end of the cables to make a moisture-proof connection between the cable and the switchgear bus. A pothead also prevents seepage of oil from the end of oil impregnated varnish cambric or paper insulated cables. See pothead manufacturer for instructions
2. Clamp type terminals and wiping sleeve or cable clamp. See cable manufacturer for instructions.

The factory does not furnish insulation materials for completing the primary cable termination at the clamp terminal or for the stress cones.

Main Bus Assembly

For 4.16 K-V, 7.6 KV, 13.8 KV, 27KV and 34.5 KV equipment:

1. Remove compartment covers.
2. Bolt splice plates and bus bars together, following assembly instructions as given under section entitled Connections. See Torque Table above and Figure below.

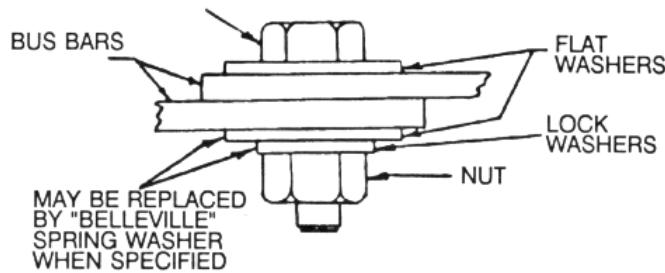

Insulated Bus Systems

MATERIALS ARE APPLIED IN SEQUENCE OF NUMBERS

- [1] Compound (4" wide)
To fill air pockets and provide a smooth base for irrathene tape
- [2] Irrathene Tape 210 (1-1/2" wide, 0.010 thick)
Beginning 1-1/4" over the end of lexan insulation, complete cover @ 2/3 seam lap - two layers

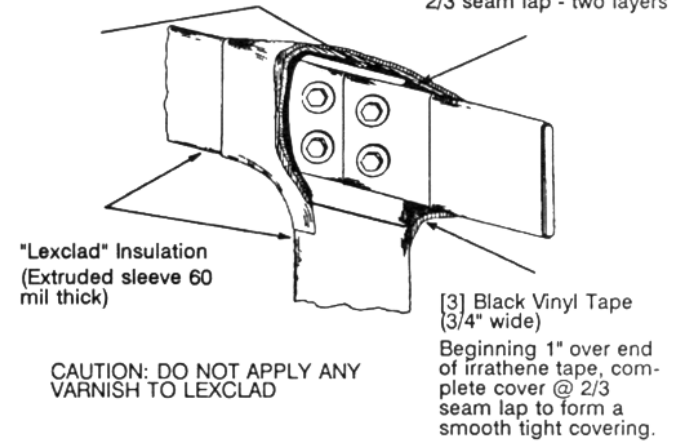

Insulated bus is provided, therefore the following must be observed. All field assembled primary joints and terminations must be insulated for the operating voltage. There are two methods of insulating joints. A detailed procedure for joint insulation is described under section entitled, "Taped Joints"

Taped Joints (When Required)

1. Prepare all joints as outlined under section entitled "Connections".
2. Fill all cavities around bolts and nuts with 4" wide filler compound to form a smooth surface for taping, thus preventing air voids. This compound is not an insulating medium and should not be used for this purpose. Cover conductors and hardware with at least 1/8" of filler.
3. Apply irrathene tape 210 (1-1/2" wide, 0.0010 thick) starting with a minimum of 1-1/2" over the end of the bus bar insulation and completely covering joint at 2/3 seam lap using two layers. Where there are sharp angles apply additional layers to obtain equivalent of the insulation on the flat surface.
4. Apply a vinyl finish tape (black or red) beginning 1" over the end of the irrathene tape, completely cover at 2/3 seam lap forming a smooth tight covering.
5. Mask off bus bar insulation and brush a heavy coat of insulating varnish over the final taping. Varnish may be thinned with Xylene.
6. Replace all covers previously removed to gain access.

BEFORE REPLACING COVERS, CAREFULLY INSPECT BUS WORK AND PHASE BARRIERS TO INSURE THAT NO TOOLS OR OTHER OBJECTS ARE ACCIDENTALLY LEFT INSIDE THE UNIT.

CAUTION

Cleaning Bus Insulation

Main bus bars when supplied are insulated with a high temperature thermoplastic material having excellent dielectric and mechanical properties.

When cleaning is necessary only denatured alcohol or isopropyl alcohol should be used to remove any foreign material from the insulation surfaces.

Primary Cables(By Customer)

Cable termination space is normally provided in the rear of the cubicle for top or bottom cable entry as shown on the drawing Adequate electrical clearance must be maintained between cables, energized parts, and grounded metal parts. It is also the installer's responsibility to adequately support cables such that insulators or bus bars do not carry the strain of the cables.

Clamp type terminals are supplied as standard and are suitable for acceptance of copper or aluminum cable.

Non-shielded portions of cable must be fully insulated from ground and any associated devices such as window CT's.

Refer to proper cable and/or termination manufacturer's instructions to make this installation.

Removable Breaker Element

After the installation of the stationary equipment is complete, the removable breaker elements should be installed in their proper compartments. Breakers are assigned to definite compartments when an order is engineered. Each breaker is assigned a part or mark number. This number is shown on the breaker sheets of the summary, the breaker nameplate, and on the identification card on the breaker shipping carton.

The removable element consists of a vacuum breaker which includes an operating mechanism, interlocks, primary and secondary disconnecting devices. The vacuum breakers are equipped with wheels for easy movement along the floor.

A lift truck (See "Lifting of Breaker") may be provided for insertion and removal of the circuit breaker from the metalclad unit.

Breakers of identical design and rating are interchangeable one with the other. An interference interlock is provided on the rear of each circuit breaker to insure that the properly rated breaker is used in the proper metalclad unit.

Breaker Racking Mechanism

When installed in the switchgear cubicle the removable element is supported by two horizontal steel tracks, one on each side of the cubicle. The racking mechanism moves the breaker element along these tracks between the connected and test positions. This mechanism consists of heavy-duty steel jack screws which carry nuts that engage the sides of the removable element. The racking mechanism may be manually operated with the racking handle which is furnished with each equipment.

The breaker cannot be moved between the connected and test positions unless it has been tripped. The breaker cannot be closed until it is in the connected or test position.

Roof Entrance Bushings

When assembling the connection bar end of roof entrance bushing inside the switchgear and other terminations when porcelain insulators are used, insulation should be applied as shown in Taped Joints.

Primary Disconnects

The 1200, 2000 and 3000 ampere primary disconnects consist of two rows of silverplated copper fingers mounted on either side of the circuit breaker studs. These fingers are held in place with a spider which positions the fingers and fastens them to the breaker. Wipe pressure is obtained by tension springs between the rows of fingers

which pulls them together. When the circuit breaker is connected to the metalclad studs, the spring force on the fingers is divided between the breaker stud and metalclad studs.

Dummy Removable Element

Dummy removable elements are used as a means of isolating circuits or bus sections where operation is infrequent and circuit breaker cannot be economically justified. The device consists of a circuit breaker mechanism frame and primary insulator supports with six primary studs including disconnecting devices. Copper rods are bolted in the location normally occupied by vacuum interrupters. The stationary structure is the same as for a circuit breaker. When the device is fully racked in, it connects the top set of metalclad primary disconnects to the bottom set.

An interlock system is provided to insure that the dummy element cannot be racked in or out, unless all sources to which it may connect are de-energized. The dummy element includes an extension from the side which is an exact duplicate of the positive interlock extension on a standard circuit breaker when that breaker is closed. Hence, insofar as the racking mechanism is concerned the dummy element looks exactly like a closed circuit breaker, and the positive interlock prevents it from being racked in or out.

A key lock is provided on the dummy element. It takes a key which becomes available only when all sources to which the dummy might connect are de-energized. When the key is available the key interlock can be operated to withdraw the positive interlock extension. The dummy element now looks like an open breaker, and it can be racked in or out. As long as the positive interlock extension is withdrawn, the key is captured and it cannot be released unless the dummy element is in the CONNECTED or TEST position or completely withdrawn. Hence, the sources to which the dummy may connect cannot be re-energized until the dummy is in one of these three positions.

The key for the dummy element interlock will usually be obtained from a transfer lock at which all the source keys are accumulated and captured before the dummy element key can be obtained.

Ground and Test Device

NOTE THAT THE MAIN SWITCHGEAR BUS IS CONNECTED TO THE LOWER STUDS WHEN THE DEVICE IS INSTALLED IN AN UPPER COMPARTMENT AND TO THE UPPER STUDS WHEN THE DEVICE IS INSTALLED IN A LOWER COMPARTMENT.

CAUTION

device is designed to make either the upper or lower primary conductors in the breaker unit readily accessible. The ground and test device provides a convenient means of grounding the cables or the bus in order to safeguard personnel who may be working on the cables or the equipment. The device can be used for applying power for high potential tests or for fault location. It can be used to measure insulation resistance (megger). By using potential transformers, it can also be used for phasing out cables. Refer to the instruction book provided for these devices. If 'hot sticks' are used they should be insulated.

OPERATION

WARNING

FAILURE TO FOLLOW INSTRUCTIONS COULD RESULT IN SERIOUS INJURY.

The metalclad switchgear provides safe operation and easy removal and replacement of the circuit breaker. Circuit breakers of the same type, rating and duplicate wiring may be interchanged.

Various interlocks are provided between the metalclad and breaker to insure safe operation. The following instructions explain how these interlocks should function. If the breaker and metalclad do not function in the manner called for in these instructions, do not force, modify, adjust or remove any interlocks. Consult the POWERCON CORPORATION Service and Installation Representative.

Breaker Installation and Removal

With all primary and control power circuits de-energized and before installing the breaker, clean the mating surfaces of the metalclad and circuit breaker primary disconnects, secondary disconnects and ground shoe and apply a thin coating of contact grease. This will prevent galling of the silvered contact surfaces.

Lifting of Breaker

1. After unpacking of breakers and checking for shipping damage and following instructions, the breakers can be moved into place.
2. Attach lifting attachment provided. By means of lifting device attach and lift. If lifting device is of your choosing it must be able to support 1000 lbs. and high enough to set breakers on rails (must be maneuverable.)
3. Open instrument panel fully and extend side rails fully, lock in place. Mount extension rails
4. Maneuver breaker above and between rails.
5. Lower breaker onto rails. Check positioning while lowering breaker.
6. Once solidly on rails, disconnect lifting attachment.
7. Push breaker into test position. Breaker will latch-in and stay secure.
8. Remove extension.
9. Lever-in or out by using following instructions.

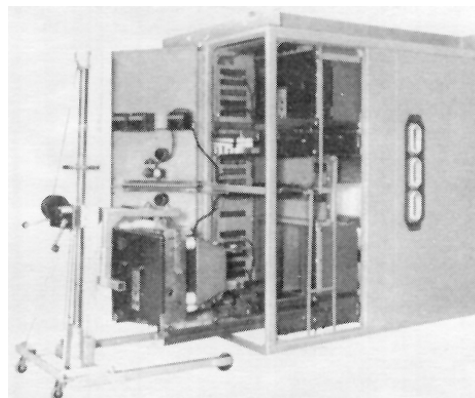

Levering Device Assembly

Operation of:

1. Advance breaker into compartment until breaker latch mates with drive block.
2. Remove extension rails.
3. Insert levering-in crank in coupling, press in and turn.
4. Turn crank, while still pressing in, until breaker stops moving in.
Note: Drive nut hits stop and the clutch begins to slip.
5. Removal of breaker is the reverse of 2,3 and 4.

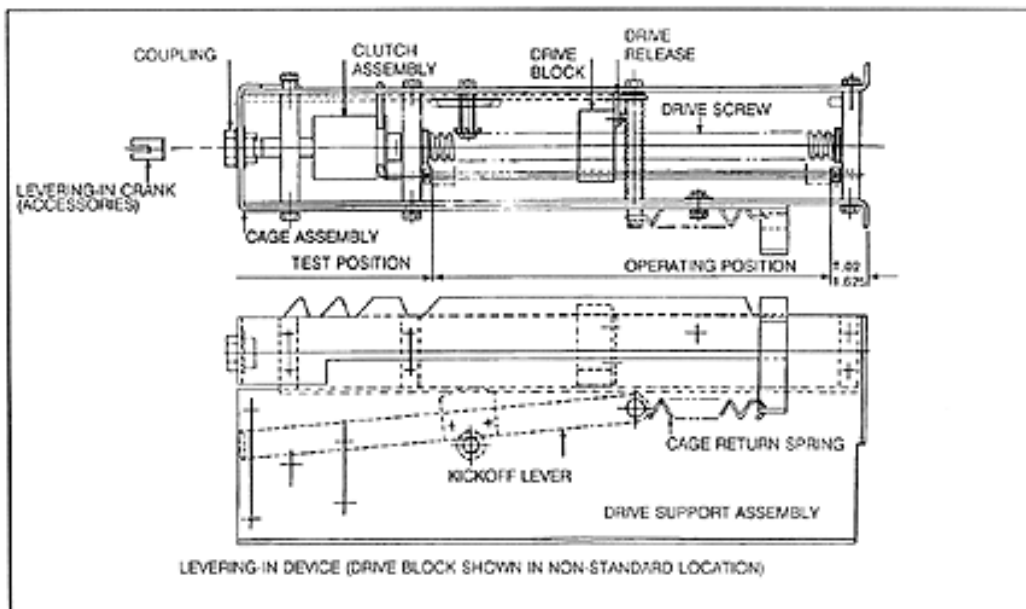

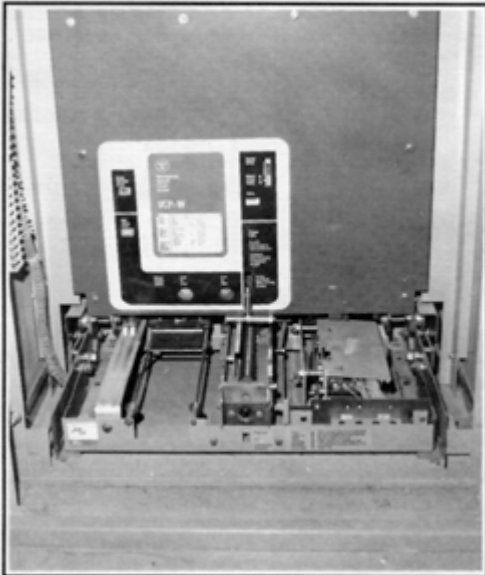

BREAKER RACKED INTO CONNECTED POSITION



BREAKER RACKED INTO INTERMEDIATE POSITION



BREAKER IN TEST POSITION

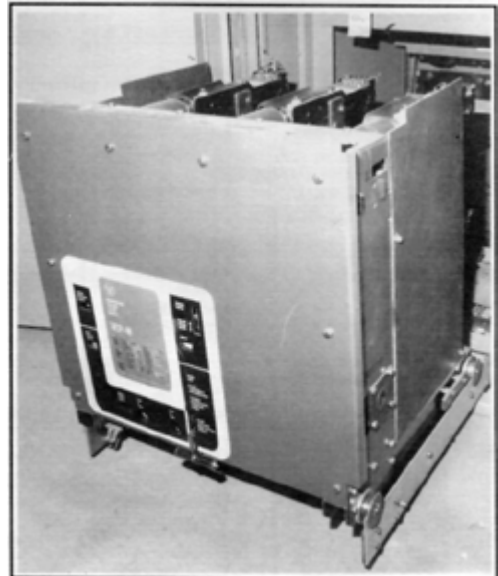

BREAKER RACKED OUT ON RAILS

Spring Discharge Interlock

The spring discharge interlock consists of a notched member in the right-side track assembly which activates the spring discharge roller on the right side of the breaker.

The function of the spring discharge interlock is to prevent the breaker closing spring from being charged unless the breaker is in the "Connect" or "Disconnect/Test" position or removed from the cubicle. In addition, it will mechanically discharge the breaker springs when the breaker is moved between any of the above mentioned positions and prevent recharging by opening the close-latch-monitoring switch in the breaker spring-charging circuit.

To test the function of the spring discharge interlock install a circuit breaker following the instructions given under "INSTALLATION". For the test the control power circuits in the metalclad must be energized.

Place the breaker in the "Disconnect/Test" position and connect the secondary disconnect device by pulling down on the breaker handle and inserting the level arm fully in the breaker. This will actuate the spring-charging motor and charge the breaker-closing springs.

Rack the breaker to the connected position using the manual racking handle. The spring discharge interlock should discharge the breaker springs in three to five turns.

Continue to rack the breaker in the connected position. Just before reaching the connected position, the spring charging motor will be re-energized and charge the closing springs. Rack the breaker toward the disconnected position. The spring discharge interlock should discharge the breaker closing springs in 3 to 5 turns. Continue to rack the breaker to the disconnect position. Re-energize the secondary disconnect device as before and this will cause the spring charging motor to charge the breaker closing springs. Raise the racking arms to the release position and roll the breaker forward. The spring discharge interlock should discharge the breaker closing springs before traveling 1/2 inch.

If the interlock does not function as indicated:

CAUTION

**DO NOT MAKE ANY ADJUSTMENTS.
COMMUNICATE WITH THE
POWERCON
CORPORATION.**

Truck-Operated Switch (TOC Switch)

The TOC switch is an assembly of one, two or three 4-pole switches. Each switch has two-make and two-break contacts. The TOC switch is mounted on the L.H. beneath the breaker ground and cover. As the breaker is being levered into the operating position, a bracket on the front of the breaker pushes the TOC switch lever during that last inch of travel. As a result, the TOC switch can be used to electrically indicate whether or not the breaker is in the operating position.

Mechanism-Operated Switch (MOC Switch)

The MOC switch is an assembly of switches that is operated by a lever on the breaker mechanism. The MOC switch is mounted beneath the cover to the right, with the operating mechanism directly to the left.

The MOC switch is activated by the breaker closing. It extends a lever out the bottom of the mechanism pushing down on the plunger of the operating mechanism. This, in turn, transmits the motion to operate switch.

Secondary Disconnecting Contacts

The control wiring is arranged for pullout disconnecting by means of two 12-point female receptacles arranged to connect male plugs on the breaker. The secondary disconnecting contacts are the connections for the control leads between the removable breaker and the stationary housing. See Breaker Instruction Book for further descriptions.

Breaker Position Interlock

The breaker position interlock is a device to prevent putting the breaker into the operation position. The position interlock is a mechanical, manually operated assembly. To operate, pull the ring at the front of pan and extend lock bolt or slide padlock clip into place.

Interference Interlock

The function of the mechanical interference interlock is to permit only breakers with the same ratings to be inserted in any specific compartment.

This interlock consists of two comb-like plates, one on the equipment and a mating plate on the breaker. The interference plate is permanently fastened to a cross member location just below the breaker mechanism frame device panel.

**TO PREVENT DAMAGE DO NOT REMOVE,
REPLACE OR RE-ADJUST THE RATING
INTERFERENCE PLATES ON EITHER THE
METALCLAD UNIT OR THE VACUUM
CIRCUIT BREAKER. IN CASE OF A
PROBLEM, CONSULT POWERCON
CORPORATION.**

CAUTION

**GAGGING CLOSING SPRINGS, WHEN
THEY ARE IN THE DISCHARGED
POSITION, CAN DAMAGE THE
THE BREAKER, THE BREAKER SIDE
FRAME MAY BE DEFORMED AND/OR THE
GEAR MOTOR MAY BE DAMAGED.**

CAUTION

Test Cabinet

The test cabinet, is used to operate a breaker that has been removed from the metalclad equipment. It should be installed on the wall at a location where maintenance and testing of the breaker can be conveniently done. Conduits must be installed for cables to supply control power for testing. Make certain that the green ground conductor is connected to the electrical ground.

Transfer Trucks

Circuit breaker transfer trucks are furnished with outdoor metalclad switchgear to facilitate moving of circuit breakers from unit to unit or to maintenance areas. The platform at the front end of the transfer truck is adjustable in height. The truck is equipped with two latches, one to hold the breaker on the truck and one to hold the truck to the metalclad switchgear unit. Both latches engage automatically, and both are released by a single T-shaped foot pedal on the rear of the truck. Depressing the left side of the pedal unlatches the truck from the switchgear unit and depressing the right side of the pedal unlatches the breaker from the truck. Trucks can be stored in breaker unit when breaker is in operating position.

TESTING AND INSPECTION

(Also see PCIB-1043 which forms part of this Instruction Book)

Testing and Inspection

After the equipment has been installed and all connections made it must be tested and inspected before putting it in service. Although the equipment and devices have been completely tested at the factory, a final field test should be made to be sure that the equipment has been properly installed and that all connections are correct. The primary equipment should be completely de-energized while the tests are in progress.

Directions for testing relays, instruments, and meters are given in the Instruction Books furnished for each device. The settings of the protective relays must be coordinated with the other relays on the system and these relays must be set by the purchaser. General instructions on setting the relays are given in the relay instruction books. Special instructions describe the sequence of operation of the devices required to perform the desired function.

The extent of the test on the equipment depends on the type and function of the equipment. Tests which should be performed on all equipments should include breaker operation, switchgear meggering, phasing and grounding checks.

High potential tests to check the integrity of the insulation are not necessary if the installation instructions are carefully followed. If this test is required by local codes or the purchaser wishes to make 60 cycle AC high potential tests, the voltage should not exceed 75% of the factory test voltage.

Potential and control power transformers must be disconnected during high voltage testing.

When transformers are furnished to supply the control power, the primary taps should be selected so that the control voltage indicated on the wiring diagram is obtained on the secondary of the transformer. When a battery is used to supply control power, the cables from the battery to the switchgear should be large enough to avoid excessive drop.

Breaker Operation Test

All breaker compartments have a TEST position in which the primary disconnects are disengaged while the secondary contacts are engaged. This position permits complete testing of the electrical control circuit without energizing the primary power circuit. When the breaker is first put into service, its control circuit should be thoroughly tested while in this position to make sure that all closing and tripping circuits are complete and functioning properly.

The TEST position is not suitable for inspection, and maintenance of the breaker and should, therefore, be used only for testing breaker operation.

Key Interlocks

After initial installation of the switchgear equipment, all necessary interlock keys should be inserted into the appropriate locks and all spare keys should be placed in the hands of a responsible person. Refer to the key interlock schematic on the front view furnished with the equipment to determine the sequence of operation and the correct number of operating keys required. This precaution is necessary since improper use of space keys will defeat the interlock scheme.

Space Heaters

Space heaters are provided in all outdoor equipment in order to keep the inside temperature several degrees higher than that outside. Heaters are also furnished for indoor equipment when it is known that abnormal atmospheric conditions exist at the installation, or when specified by the purchaser.

By maintaining a slight temperature differential, the heaters help facilitate drying and prevent condensation and the resulting corrosion and insulation deterioration which might occur.

Heaters are normally located in the breaker units, a few inches above the floor. In auxiliary compartments with a single rollout, the heaters will be in a space above the rollout. In auxiliary compartments with two rollouts, the heater will be in a space between the rollouts. Heaters may also be located in superstructure compartments, transition compartments, and in bus ducts if the operating conditions require them.

Before energizing the heaters, be sure the power source is of the proper voltage, frequency, and phase arrangement, and is connected in accordance with the wiring diagrams furnished with the equipment. Also, be sure to remove all cartons and miscellaneous material packed inside the units before energizing the heaters.

Heaters should be visually inspected several times a year to make sure they are operating properly.

It is recommended that the heaters be energized at all times and that thermostatic control not be used.

Fuse Carriage

Control Power Transformer Fuses

A non-automatic molded cut breaker and associated fuses are

mounted in the auxiliary compartment. The breaker is connected in series with the transformer secondary winding so that all secondary load is removed when the breaker is opened. A key lock is mounted with the breaker in such a manner that the key can be removed only when the breaker is open. The key is then used to unlock the fuse carriage key lock on the front of the carriage. This permits carriage to be withdrawn to disconnect the primary fuses. This key is now held in lock and cannot be removed until carriage is returned to connected position. Ground devices contact the end of the fuses to effectively remove all charges from the fuses

INSPECTION AND MAINTENANCE

For inspection and maintenance procedures see PCIB-1043 which forms a part of these instructions.

A regular maintenance schedule should be established to obtain the best service and reliability from the switchgear. An annual check and overall maintenance procedure for the switchgear, devices and all connections should be followed as a minimum requirement. Equipment subject to highly repetitive operation may require more frequent maintenance.

A permanent record of all maintenance work should be kept, the degree of detail depending on the operating conditions. In any event, it will be a valuable reference for subsequent maintenance work and for station operation. It is recommended that the record include reports of tests made, the condition of equipment and repairs and adjustments that were made.

BEFORE ANY COVERS ARE REMOVED OR ANY DOORS OPENED WHICH PERMIT ACCESS TO THE PRIMARY CIRCUITS, IT IS ESSENTIAL THAT THE CIRCUIT(S) BE DE-ENERGIZED AND BREAKERS BE WITHDRAWN TO THE TEST POSITION AND TAGGED.

WARNING

The primary circuits of metalclad switchgear are insulated in order to reduce the size of the equipment. However, this insulation, except in one or two instances, requires a certain amount of air gap between phases and to ground to complete the insulation. Inserting any object in this air space, when equipment is energized, whether it be a tool or a part of the body, may in certain conditions, short circuit this air gap and may cause a breakdown in the primary circuit to ground and cause serious damage or injury or both.

Recommended Annual Maintenance

The switchgear structure and connections should be given the following overall maintenance at least annually. All maintenance work must be done with both the primary and control power circuits deenergized.

1. Thoroughly clean the equipment, preferably using a heavy duty vacuum cleaner to remove all dust and other accumulations.
2. Clean racking mechanism and lubricate jack screws and gears with lubricant.
3. Check primary disconnecting device contacts for signs of abnormal wear or overheating. Discolorations of the silvered surfaces is not ordinarily harmful unless atmospheric conditions

cause deposits such as sulphides on the contacts. If necessary the deposits can be removed with a good grade of silver polish. Sandpaper, steel wool, or abrasive cleaners should never be used on silverplated. Before replacing breaker, apply a thin coat of contact lubricant to breaker studs.

4. Check tightness and continuity of all control connections and wiring.

Instrument Compartments

Breakers

1. Test and inspect all breakers for proper operations as follows:

WARNING

**DE-ENERGIZE
EQUIPMENT
COMPLETELY EXCEPT
FOR TEST CIRCUITS**

Operate each breaker while in the TEST position and check all functions. This is particularly important for breakers that normally remain in either the open or closed position for long periods of time.

2. Remove the breaker from its compartment to a clean maintenance area. The test cabinet provides a convenient means for operating the breakers when they are removed from the compartments. The maintenance operation should be performed in accordance with the procedure suggested in the appropriate breaker maintenance manual.

Instruments, Instrument Transformers & Relays

Since under normal conditions, the protective relays do not operate, it is important that the operation of these devices be checked regularly. Check and inspect all devices to see that they are functioning properly. Check device mounting. Check that all electrical connections are tight.

Breaker Compartment Interiors

1. Thoroughly clean the interior of the breaker and instrument compartments. Use a vacuum cleaner and clean rags only. Do not use steel wool or oxide papers. Blowing with compressed air is not recommended

2. Check indicating devices, mechanical and key interlocks.
3. Check primary disconnecting device contacts for signs of abnormal wear or overheating. Discoloration of the silver surfaces is not normally harmful unless atmospheric conditions cause deposits such as sulphides on the contact surfaces. If necessary, deposits can be removed with a good grade of silver polish. Otherwise, wiping with a lint-free cloth will suffice. Before replacing the breaker, apply a thin coat of contact lubricant to the house studs and the ringer disconnects on the breaker.

Bus Compartment

1. Remove covers and check buses and connections or evidence of overheating or weakening of the insulation.
2. Check that all bus mounting bolts and splice connection bolts are tight.
3. After cleaning, megger and record the resistance to ground and between phases of the insulation of buses and connections. Since definite limits cannot be given for satisfactory insulation resistance values, a record should be kept of the reading. Weakening of the insulation from one maintenance period to the next can be recognized from the recorded readings. The readings should be taken under similar conditions each time and the record should include temperature and humidity.

RENEWAL PARTS

Ordering Instructions

Renewal parts should be ordered from the POWERCON CORPORATION.

Specify the quantity, reference number, description, and this PCIB number.

Standard hardware, such as screws, bolts, nuts, washers, are not listed. Such items should be purchased locally.

For prices, refer to the POWERCON CORPORATION.

If parts listed separately are to be assembled at the factory, order must so state.

Not all parts shown herein will be used on any one equipment,. Parts not used in original equipment should be ordered as renewal parts.

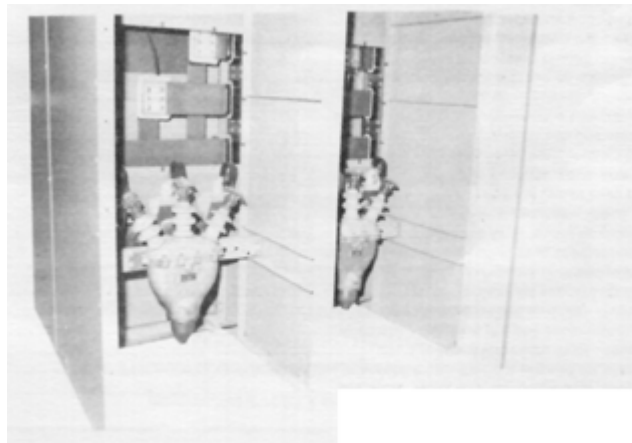

CABLE ENTRY COMPARTMENT WITH MAIN BUS COVERS REMOVED



INSTALLATION OR PLANNED MAINTENANCE SWITCHGEAR CHECKLIST

CUSTOMER: ORDER NO.: DATE:
SWITCHGEAR IDENTIFICATION
MANUFACTURER: SHOP ORDER NO.
DRAWINGS: VOLTAGE CLASS: TYPE:
LOCATION: CUBICLE NUMBER: CUSTOMER ID:
APPLICATION:
EXTERNAL CONDITION: [] GOOD [] FAIR [] POOR
CONSISTING OF: [] TOTAL BREAKERS [] TOTAL RELAYS [] TOTAL INSTRUMENTS [] MOLDED CASE BREAKERS

- 1. General Inspection of exterior of equipment []
2. Check panel lights for operation - burned out or missing bulbs and lamp covers []
3. Check control knobs and switches for freedom of movement and contact conditions []
4. Inspect for damaged, bent or twisted doors []
5. Inspect door handle, locking bars and mechanisms []
6. Check door interlocks for positive operation []
7. Inspect for broken instruments and relay glass cover, & burned out phase indicator lights []
8. Inspect for proper grounding equipment []
9. Inspect and megger power cable or bus to switchgear []
10. Measure resistance to ground []
11. Dielectric test of cables - bus work and potheads []
12. Inspect bus and support insulators []
13. Torque test bolted bus (Exposed connections only) []
14. Clean bus insulators - megger test for grounds []
15. Inspect control and metering transformers []
16. Radio test transformers []
17. Check resistors - grid assemblies and space heaters []
18. Check condition of wiring and terminal connections []
19. Report unsafe conditions []
20. Check bus for support and spacing []
21. Note and report any unmarked circuits []
22. Remove drawout circuit breakers []
23. Check rails, guides, rollers and shutter mechanisms []
24. Lubricate drawout assembly parts []
25. Check cell interlocks and auxiliary contact assemblies []
26. Inspect breaker and cell contacts []
27. Vacuum and clean interior of cubicle []
28. Perform breaker inspection and test []
29. Test molded case circuit breakers []
30. Inspect and check instruments []
31. Note and record as found, relay settings []
32. Determine correctness of settings - if improperly set, advise customer []
33. Restore control power to switchgear []
34. Check relays for positive tripping []
35. Test annunciator - alarm or target operation []
36. Operate controls - close and trip breakers electrically []
37. Check automatic relay operation (if used) []
38. Re-check relays for positive tripping with breakers in test positions []
39. Make final visual inspection, remove loads, tools, etc. []



1551 FLORIDA AVE.
P.O. BOX 477
SEVERN, MD 21144
410-551-6500

EMAIL: info@powerconcorp.com
http://www.powerconcorp.com