

POWERCON CORPORATION

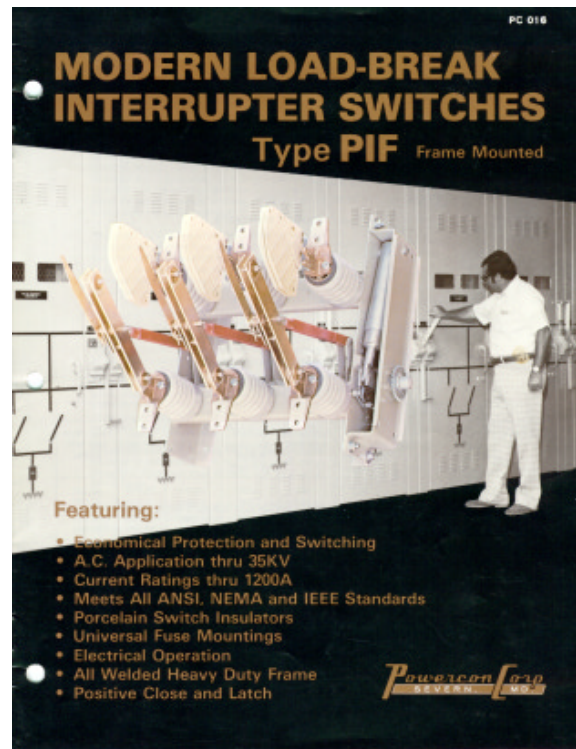

MODERN LOAD-BREAK INTERRUPTER SWITCHES, TYPE PIF

BROCHURE #PC-016

ELECTRONIC VERSION CREATED: 7/21/96

**Powercon Corporation
P.O. Box 477
1551 Florida Avenue
Severn, Maryland 21144
Baltimore: 410-551-6500
Washington: 301-621-7400
Fax: 410-551-8451
<http://www.powerconcorp.com>
email: info@powerconcorp.com**

APPLICATION

Powercon Load Break Interrupter Switches are applied in the control and switching of Power distribution Systems having nominal a.c. voltage ratings from 2.4kV to 34.5kV. They are capable of switching 600 & 1200 amperes. Table 1 lists the applicable limits and conditions of switching. These switches are available with either electrical or mechanical operators. When used in conjunction with fuses they will afford overload, short circuit and disconnect services. These switches are used:

- On the primary of transformers for their protection and isolation
- For the protection and isolation of single circuit systems.
- For the protection and isolation of multi-circuit systems
- For automatic transfer schemes where their ratings are not exceeded.

APPLICABLE INDUSTRY STANDARDS:

- NEMA SG-5 - Power Switchgear Assemblies
- NEMA SG-6 - Power Switching Equipment
- NEMA C37.20 - Switchgear Assemblies
- NEMA C37.30 - Requirements for High Voltage Air Switches
- NEMA C37.31 - Indoor Apparatus Insulators for High Voltage Switches
- NEMA C37.33 - Preferred Ratings and Mfg. Specs for High Voltage Switches
- ANSI C37.33 - Rated Control Voltages and Ranges for High Voltage Switches
- ANSI C37.34 - Test Code for High Voltage Air Switches

Table 1.
INDOOR AIR INTERRUPTER SWITCH RATINGS
 (These ratings apply to switches and equipment with stored energy operated switches)
 (Special ratings available - consult factory)

Voltage Ratings				Current Ratings				
Nominal KV RMS	Max. Design KV RMS	1 Min. Power Freq. Withstand KV RMS	1.2 X 50 Impulse Withstand KV BIL	Continu ous AMP RMS	Contact Interrup ting Rating AMP RMS	Moment ary AMP RMS ASYM.	3 Sec. AMP RMS	Fault Close AMP RMS ASYM.
4.16	4.76	19	60	600 1200	600 1200	40000 61000	25000 38000	40000 61000
7.2	8.25	26	75	600 1200	600 1200	4000 61000	25000 38000	40000 61000
13.8	17.0	36	95	600 1200	600 1200	40000 61000	25000 38000	40000 61000
14.4	17.0	50	110	600 1200	600 1200	40000 61000	25000 38000	40000 61000
23.0	25.8	60	125	600 1200	600 600	40000 40000	25000 25000	40000 40000
34.5	38.0	80	150	600 1200	600 600	40000 40000	25000 25000	40000 40000
34.5	38.0	95	200	600 1200	600 600	40000 40000	25000 25000	40000 40000

NOTE: 60,000 Ampere Momentary Ratings are available on request for 600 Ampere Switches

PIF FRAME MOUNTED HEAVY DUTY RUGGED INDUSTRIAL LOAD BREAK SWITCHES WITH SUPERIOR FEATURES PROVIDE:

- Unequaled Dependability
- Minimum Maintenance
- Long Interrupting Life
- Greater Safety
- Simple to Install and Operate



ARCING CHAMBERS

Tungsten material stationary arcing contacts are located inside the arc chutes. They remain at the same potential as the main stationary contact. As the quick break blade is withdrawn from the arc chute it parts with the stationary arcing contacts inside the chute. The chute is made from a specially prepared compound that evolves a gas to quickly extinguish the arc. Clean consistent interruptions result. No appreciable amounts of gas are evolved.

MAIN MOVEABLE BLADES

These blades are made of 99% conductivity hard drawn ETP copper bars and they are heavily silver-plated at the contact points for long dependable operation.

QUICK BREAK BLADE

The quick break arcing blade is made of a special high strength, hi conductivity material tipped with a tungsten arcing material. A quick break spring charging mechanism is mounted on the blade that with an assist from the arcing chamber stationary contacts prevents the opening until after the main contacts part at the proper clearance spacing.

PORCELAIN SWITCH INSULATORS

The near ULTIMATE in insulation

Wet process porcelain is used as the insulating support for the main hinge and jaw contacts. Porcelain is a tried and true material proven in service as the near ultimate in insulation. It has excellent dielectric characteristics, is non-tracking, non-combustible, non-hygroscopic, won't age, and is easy to clean. No organic materials can compare to the performance of porcelain.

A SUPER STRUCTURE

Powercon's all welded frame design provides a ruggedness and greater structural strength which is in a class by itself. The jig welded structural members form an assembly to provide a plumb and square switch unit. This assures interchangeability of units and results in a minimum of installation time.

STATIONARY ARCING TIPS

Powercon arcing blades and tips are designed to prevent arcing blades from hanging up in the stationary arcing contacts. Successful tests with welded stationary contacts have been made and it has been successfully demonstrated that these tips do not hang up.

STATIONARY CONTACTS

Both Hinge and Jaw contacts are heavy copper castings capable of absorbing and dissipating the heating from the large short circuits which may be encountered. The contact pressure is maintained on these contacts with selected spring washers especially adapted to maintain suitable pressure for many operations and over many years of operational performance. The retaining nuts are Elastic Stop Nuts to prevent vibration, shock, and operation loosening the joint. Special dirt sealing designs effectively prevent the entrance of dust or dirt into the contact making area. The contact area is silver to silver to maintain optimum current carrying ability and decrease heating.

STORED ENERGY MECHANISM

The powerful opening and closing springs of Powercon's off-center stored energy mechanism provides for quick make (rated fault closing) and quick break (rated load interruption). The switch mechanism shaft is driven by a chain and sprocket from the front operating handle. As the handle is rotated, it is directly connected to a sprocket which in turn, chain drives the opening spring to a "charged" position. As the operator continues to rotate the handle, the charged spring is driven off-center by the chain and releases its energy into rotating the operating shaft to operate. The switch blades will not move, in either a closing or opening direction, until the closing spring causes rotation in the operating shaft. It should be noted, that once the springs are moved off-center, the operator has no further control of the opening and closing operation. He therefore has a fault closing and rated load break feature independent of his performance. ANTI-FRICTION BEARINGS provide for a smooth operating performance.

SPECIFICATIONS	SPECIAL FEATURES and AVAILABLE ACCESSORIES
<p>Air interrupter switches shall be group operated of the stored energy type, 3 pole single throw, utilizing a direct acting spring charged mechanism for both closing and opening functions. Switch mechanisms shall be operable externally from the front or side of the cubicle and shall be equipped with a quick-make quick-break mechanism to open and close the switch independent of the speed with which the operating handle is moved. "Teasing" of the switch poles will not be permitted.</p> <p>They shall have main and arcing contacts and be designed to provide maximum endurance for load interrupting and fault closing. The arcing contacts shall be spring loaded on break and shall be last in last out. They shall operate in an arc chute designed to assist in interruption, & liberate no appreciable gases on interruption.</p> <p>All components except operating handle system shall be mounted on a jig welded frame to form a rugged unitized assembly accomplished in jigs & fixtures to insure all parts function as required. A strict quality control program shall be instituted & followed.</p> <p>The main blades shall be made of electrolytically pure cold rolled copper. All contact points shall be heavily silver plated on blades as well as the hinge & jaw castings. These contacts each will be one piece castings to provide maximum heat dissipation & continuous current transfer.</p> <p>W& process porcelain insulators shall be used to insulate the hinge & jaw castings from the frame on all rating, above 5KV. Reinforced glass polyester shall be used on 5KV & below.</p> <p>Rating of interrupter switches shall be as outlined in table page 1 of this publication. When used with fuses ratings shall be dependent upon specified fuse characteristics.</p> <p>The switch shall conform to or exceed ANSI Standards for high-voltage air switches and switchgear assemblies C37,30-1971, C37.32-1972, C37.34-1970, C37.20C-1974. Upon request, certified test reports shall be provided, proving published interrupting, short-time, momentary, BIL, dielectric and fault-closing ratings.</p> <p>All components of the switch shall be completely checked and operated in compliance with documented quality assurance procedure to insure that all parts function as intended after manufacture and assembly. Testing shall consist of power frequency withstand and mechanical operations.</p>	<p>Electrical Operators:</p> <ul style="list-style-type: none"> • Standard Close - Standard Open • Quick Close - Standard Open • Standard Close - Quick Trip- • Quick Close - Quick Trip- <p>Manual Operators:</p> <ul style="list-style-type: none"> • Manual Close - Quick Trip (Electric)- • Manual Quick Close - Standard Open- • Manual Close - Manual Quick Trip- <p>Mounting</p> <ul style="list-style-type: none"> • Inverted • 2 High Stack • Horizontal • Extended Side Frames <p>Handles</p> <ul style="list-style-type: none"> • Removable • Left Side • Direct Drive • Drilling for Keylocks <p>Insulation</p> <ul style="list-style-type: none"> • Porcelain for 5KV and Below o 1 10KV BIL for 7.2KV thru 15KV <p>Accessories</p> <ul style="list-style-type: none"> • Phase Barriers • Ground Bales • Universal Fuse Hinge Castings e key Interlocks • Cable Connectors <p>Consult factory for special arrangements and applications.</p> <p>*In accord with industry standards, a deliberate time delay between closing and opening must be provided in these switches. Accordingly, in order to open the switch, the opening springs must be charged after the switch is closed and vice versa to introduce this time delay.</p>

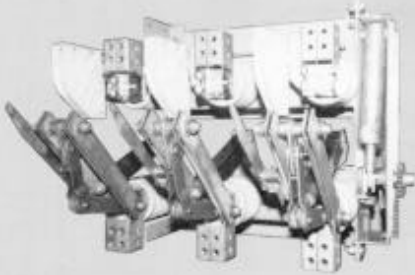

15KV - 2000A CONT.-1200A INT.

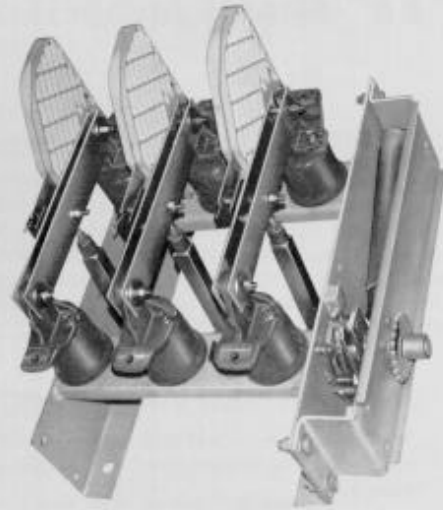

5KV - 600A A - 3 PST



15KV - 600A

Complete with Universal Fuse Castings
and Side Mounts.
Note: Application 3 different Fuses.



38KV - 200KV BIL - 600A - 3 PST

DIMENSIONS AND WEIGHTS*

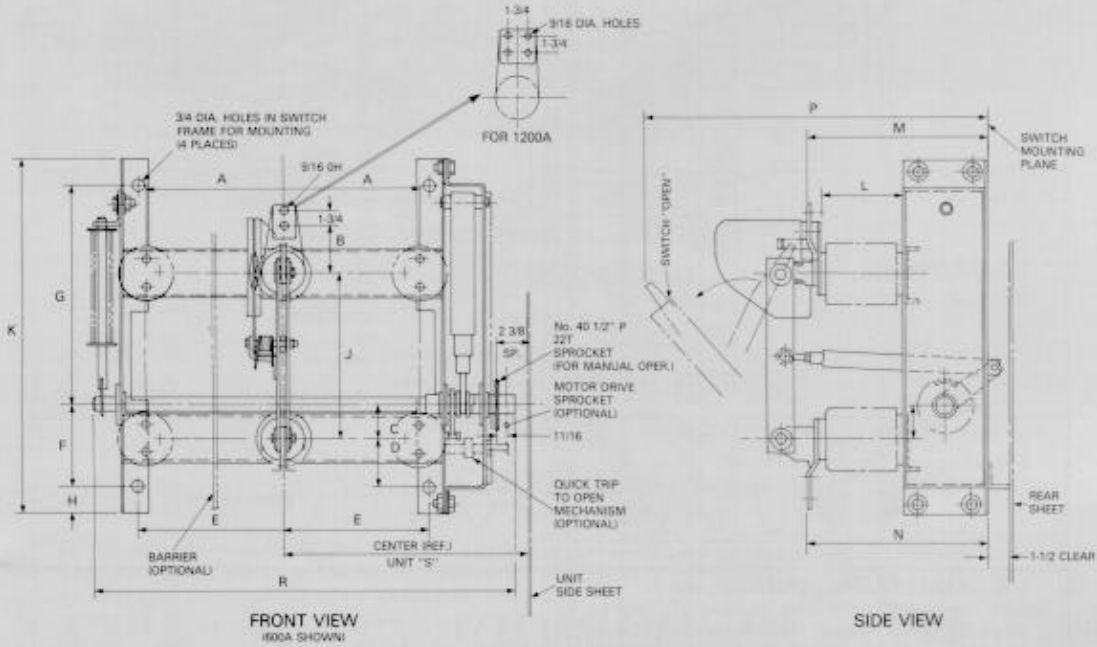

SWITCH CLASS	DIMENSIONS* 3 PST — (INCHES/METRIC)															BASIC WEIGHT		
	A	B	C	D	E	F	G	H	J	K	L	M	N	P	R		S	
5KV - 600 A 60KV BL	IN MM	6.00 152	2.75 70	2.50 63.5	3.50 89	6.62 168	6.00 152	12.38 314	2.00 50.8	12.00 305	25.88 657	3.50 89	10.75 273	10.62 270	23.0 584	22.4 569	14.0 356	135 LB - 61KG
5KV - 1200 A 60KV BL	IN MM	6.00 152	2.75 70	2.50 63.5	3.50 89	6.62 168	6.00 152	12.38 314	2.00 50.8	12.00 305	25.88 657	3.50 89	10.75 273	10.62 270	23.0 584	22.4 569	14.0 356	150 LB - 68KG
15KV - 600A 95KV BL	IN MM	10.00 254	2.75 70	2.50 63.5	3.50 89	10.62 270	6.00 152	15.88 403	2.00 50.8	12.00 305	25.88 657	6.00 152	13.25 336	13.12 333	27.6 701	30.8 782	18.0 457	165 LB - 75KG
15KV - 1200A 95KV BL	IN MM	10.00 254	2.75 70	2.50 63.5	3.50 89	10.62 270	6.00 152	15.88 403	2.00 50.8	12.00 305	25.88 657	6.00 152	13.25 336	13.12 333	27.6 701	30.8 782	18.0 457	180 LB - 81.8KG
*20KV - 600A 125KV BL	IN MM	13.00 330	3.25 83	4.75 121	3.50 89	13.90 343	8.25 210	19.50 495	1.00 25	18.00 457	29.75 756	10.5 267	21.1 536	20.88 530	40.00 1016	40.00 1016	24.00 610	300 LB - 136KG
*23KV - 1200A 125KV BL	IN MM	13.00 330	3.25 83	4.75 121	3.50 89	13.90 343	8.25 210	19.50 495	1.00 25	18.00 457	29.75 756	10.5 267	21.1 536	20.88 530	40.00 1016	40.00 1016	24.00 610	320 LB - 145KG
38KV - 600A 150KV BL	IN MM	16.00 406	3.25 83	6.34 161	5.00 127	19.75 502	11.34 289	30.03 763	1.00 25	26.00 660	43.38 1102	10.5 267	24.19 614	24.00 610	48.50 1257	52.81 1341	30.00 762	400 LB - 181KG
38KV - 600A 200KV BL	IN MM	18.00 457	3.25 83	6.34 161	5.00 127	24.75 629	11.34 289	30.03 763	1.00 25	26.00 660	43.38 1102	10.5 267	28.69 729	28.5 724	54.00 1372	62.81 1595	35.00 889	460 LB - 209KG

* NOT CERTIFIED FOR CONSTRUCTION — FOR ESTIMATING PURPOSES ONLY

INTERRUPTER SWITCH TESTS REPRESENTATIVE CURVES

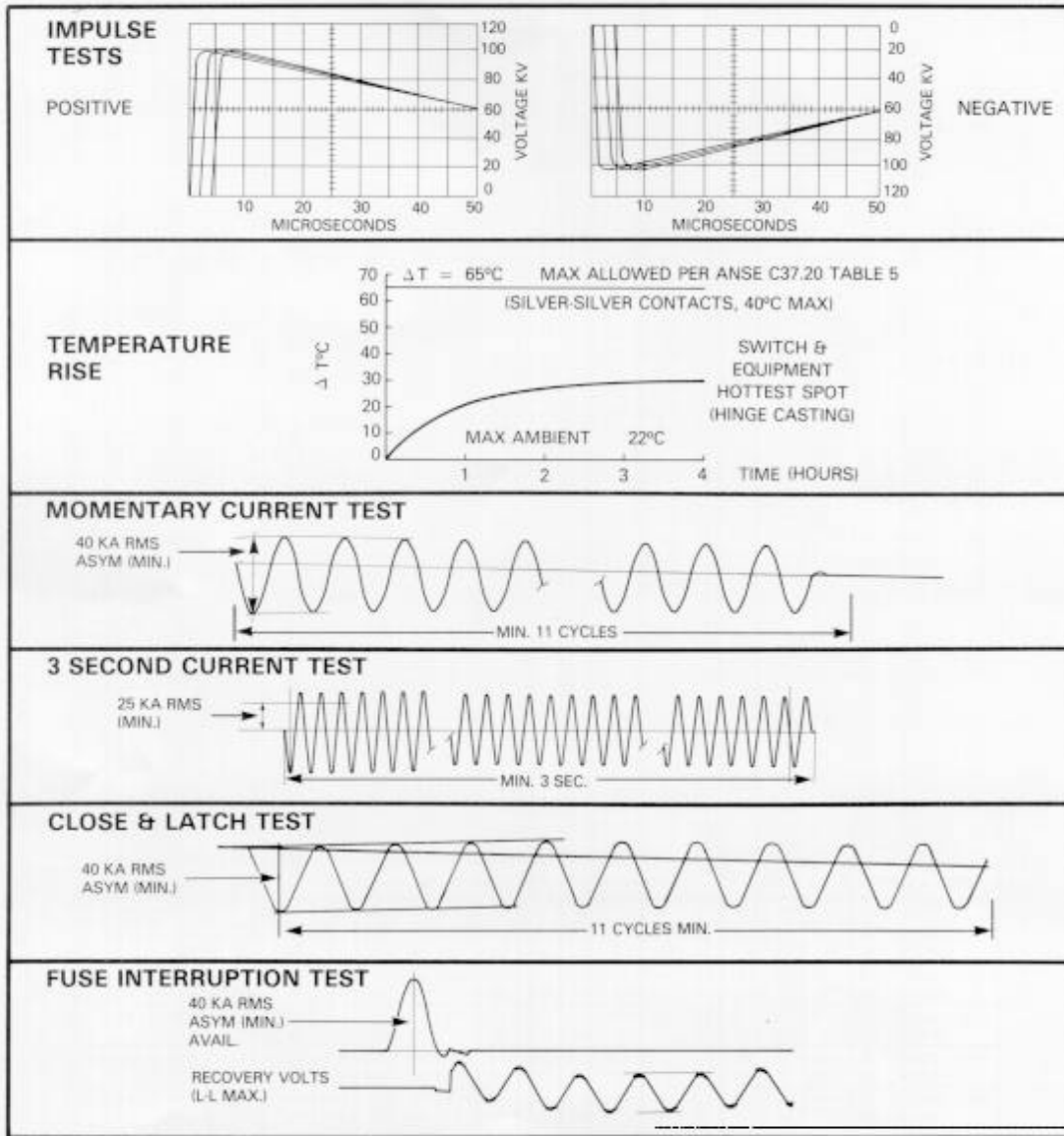

All Certified Test Reports are available for inspection at Powercon factory.

Other tests, such as Mechanical Life Tests, Timing Tests, Magnetizing Tests, Load Switching Tests, etc. have been completed and are available at the Powercon factory.

All High Power Tests made at G.E. or Westinghouse Hi-Power Laboratories.

ORDERING DATA

Specify the Following:

1. Voltage
2. Continuous Current F± Interrupting Rating
3. Close & Latch Rating
4. Frequency & Poles
5. Manual or Electrical Operation
(Specify Control Voltage for Electrical Operators)
6. Handle Arrangement
7. Optional Accessories

NOTES

1. The enclosure and insulating-barrier dimensions listed herein have been determined using the *minimum* clearances (shown in Note 4) recommended to maintain the inherent electrical ratings of Powercon type PIF Switches when installed in metal enclosures. These clearances are sufficient provided that normal consideration has been given to avoidance of point-gap configurations. When installing bus or cable connections and cable terminations, these clearances should be observed.
2. For enclosures wherein PIF Switches are to be combined with Power Fuses in a "switch-over-fuse" configuration, recommended minimum fuse-component clearances may govern in determining the enclosure dimensions.
3. For enclosures wherein Powercon PIF Switches are to be combined with Power Fuses in a "fuse-over-switch" configuration, consult the Powercon Corp.
4. If the complete assembly consisting of enclosure, switch, barriers, bus, connectors, terminators, etc. is not impulse tested to verify that it will fully meet its assigned BIL rating, the assembly should be checked to ensure that the following minimum recommended clearances have been met or exceeded. Greater clearances may be required if corners, edges, or small radius, points exist.

Switch Rating, Kv, BIL	Minimum Recommended Clearances, Inches		
	Metal-to Metal* (Phase to phase, phase to phase ground)	Energized part to Barrier	Barrier to Ground (in vicinity of energized parts)
60	3.5	.75	.75
95	6	1.5	1.5
125	8.5	2.5	2.5
150	10.5	3.5	3.5
200	15	5	5

5. In as much as Powercon has no control over the use to which others may put this material, responsibility for its application and compliance with the applicable standards and codes of the final enclosed assembly will not be assumed by Powercon. The disconnect switches will perform as described herein when used with the proper technology, application, and maintenance.



SWITCH ASSEMBLY AND INSPECTION

Build in quality is that quality which must be checked and tested every step of manufacturing in order to assure quality of operation. All parts are manufactured with forming tools, welded in precise fixtures, subassembled and assembled in exacting jigs. Each subassembly is carefully monitored and finally as shown in the test stands at the left, the completed assembly is given a final adjustment and inspection. A high potential test is finally given after paint touch up and the switch certified for shipment. These rigid quality control procedures and constant attention to detail provides Powecon with the reputation for quality that can be taken for granted.

Powecon's experience in over 15 years of building switches and the associated technical organization gives it the enviable reputation of having successfully satisfied installers worldwide.

Some of the foremost switch manufacturers in the country have turned to the superior Powecon switching equipment.

Powecon SEVERN MDU



P.O. Box 477 • Severn, Maryland 21144 • A/C 410-551-6500 • Fax 410-551-6451